



Detailed Modeling and Novel Scheduling of Plug-in Electric Vehicle Energy Storage Systems for Energy Management of Multi-micro grids Considering the Probability of Fault Occurrence

Peyman Bayat¹, Hossein Afrakhte^{2*}

¹ Ph.D. Student, Department of Electrical Engineering, University of Guilan, Rasht, Iran

² Associate Professor, Department of Electrical Engineering, University of Guilan, Rasht, Iran

ARTICLE INFO

Article history:

Received: 11 June 2019

Accepted: 26 Aug 2019

Published: 1 Sept, 2019

Keywords:

Plug-in electric vehicles (PEVs)

Plug-in hybrid electric vehicles (PHEVs)

Energy storage system

Multi-microgrid (MMG)

Energy management

ABSTRACT

As an effective means of displacing fossil fuel consumption and reducing greenhouse gas emissions, plug-in electric vehicles (PEVs) and plug-in hybrid electric vehicles (PHEVs) have attracted more and more attentions. From the power grid perspective, PHEVs and PEVs equipped with batteries can also be used as energy storage facilities, due to the fact that, these vehicles are parked most of the time. Since, the temperature has a strong influence on the battery life-time and also the inherent characteristics of PHEV/PEV energy storage systems limit their use as appropriate resources for energy tuning, this paper, at first, presents a detailed model for energy storage systems of PEVs considering the cooling system and set temperature, and then, it proposes a reliable energy management method for scheduling of PEVs in the multi-microgrid (MMG) systems for both faulted and normal operations using parametric multi-objective function. The simulation results indicate that, considering proper energy management of energy storage systems of PEVs has significant influence on energy scheduling of MMG systems. For this investigation, all data analysis and simulations were done and implemented in MATLAB/Simulink environment.

1. Introduction

As a convenient solution to the challenges of fossil fuels energy consumption and the global warming problem, renewable energy has been experiencing rapid development over the last few years [1]. By integrating the distributed renewable energy sources (RESs) and other resources, the conception of microgrid (MG) was proposed as an effective way to integrate renewable energy into the grid [2]. However, intermittent and randomness of RESs have a negative influence on the stability of power networks [3,4]. So, energy storage units have always been suggested to deal with these problems and guarantee of power supply.

On the other hand, the number of plug-in electric vehicles (PEVs) and plug-in hybrid electric vehicles (PHEVs) have increased quickly

during the last decade [5]. Since PEVs and PHEVs can be used as distributed energy storage systems, they can be a unique solution to overcome with the non-alternating nature of RESs and can further facilitate the development of these units; Also, with proper control and coordination of PHEVs and PEVs in the predetermined parking lots, they can be appropriately used to improve the power system efficiency [6]. In this context, these kind of vehicles, can have the charging or discharging modes depending on the power system loading conditions and their current states of charge (SOC) [7,8]. Also, as illustrated in Figure 1, in the perspective of electricity market, they can play a dual role: grid to vehicle (G2V) when their batteries are charged and vehicle to grid (V2G) when they export their surplus energy to grid [9]. Since most PEVs are in the parking lots more than 22 hours per day [10], they can

* Hossein Afrakhte

Email Address: ho_afrakhte@guilan.ac.ir

DOI: 10.22068/ijae.9.3.3045

adequately play both aforementioned roles. However, since each PEV has its own conditions, an efficient energy management is needed to manage all PEVs in a coordinated manner. To address this issue, several investigations have been down in the articles [11-13].

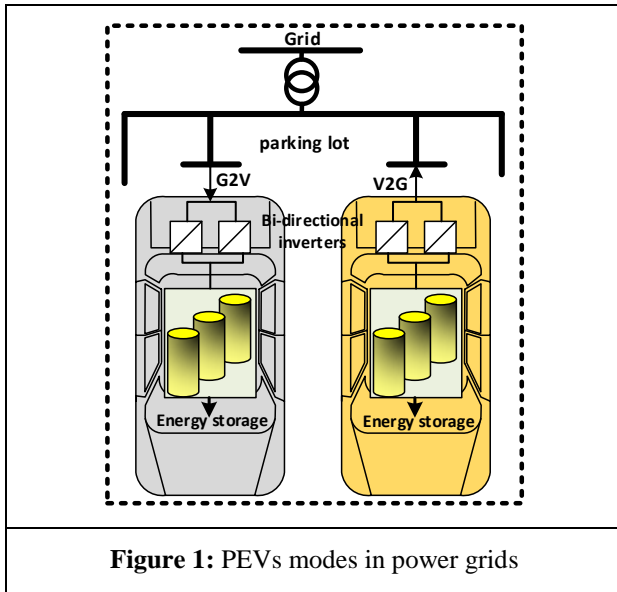

Figure 1: PEVs modes in power grids

Some researchers have focused on the potential impacts of PHEVs on the energy efficiency of power systems. In Ref. [14] the proper time-of-use electricity rates was designed to reduce the peak demand of residential customers considering the different PHEVs penetration levels. The impact of the PEVs battery charging on the load demand in the typical distribution systems is modeled in [15]. In Ref. [16], a model-based design method was introduced to simplify the implementation of control algorithm on the energy management system of PHEV. The impact of PHEVs charging power on a typical distribution grid is investigated in [17]. The appropriate model for studies of PHEV usage, infrastructure model for smart charging concepts and home-charging model have been respectively presented in [18-20]. The authors of [21] proposed a predictive control approach for a MG frequency stabilization considering V2G concept. In doing so, charging and discharging mechanism of PHEVs were performed by optimizing the PHEV's control signals according to their corresponding battery's SOC. Reference [22] also proposed the energy management strategy for V2G regulation services using dynamic programming. For this work, battery model of PHEVs is integrated with energy cost and hourly demands in V2G scenario aiming to flatten the load curve. Also, the authors of [23] used particle swarm optimization technique to develop an optimized control algorithm for energy management of PHEVs in smart MGs considering

the stochastic nature of such vehicles. Similarly, the load management problem in micro distribution systems is investigated in Ref. [24]; for this work, the authors have proposed a fuzzy petri-net approach to detect nontechnical losses, outage events and fraudulent consumptions. From the energy management of multi-microgrid (MMG) view point, reference [25] investigated the impact of PEVs in improving the reliability of modern distribution systems during contingency faults. In the same vein, suitable centralized and decentralized methods are introduced in [26,27] to optimized energy management of MMG systems during unpredictable outage events.

Lithium-ion batteries are nowadays most widely used in many PEVs and PHEVs due to their high gravimetric and volumetric energy density. Some researchers have addressed the relationship of Lithium-ion battery packs with environment temperature. For example, the authors in [28] try to predict the capacity of lithium-ion battery packs at different temperatures. In [29], the performance and life cycle of lithium-ion batteries were analyzed in various temperatures. In [30], researchers presented a theoretical model for a lithium-ion battery considering the thermal condition. However, the impact of cells temperature on the discharge characteristic, open-circuit voltage and internal resistance is not considered.

From another point of view, batteries of PEVs and PHEVs are designed basically for the traction mode of vehicles, and not for the application of energy storage in power grids; therefore, they cannot be used like battery energy storage systems installed in the grids. Also, frequent charging and discharging of batteries causes degradation of cell performance and reduction of rated life cycles; eventually, network operators need to periodically swap the battery packs. Therefore, while designing energy management systems for operation of power grids, the implications of battery degradation and battery pack temperature must be taken into account. For this reason, in this paper, at first a detailed model for energy storage system of PEVs considering the cooling system is presented. Then, a novel hierarchical energy management strategy for scheduling of PEVs in a MMG is proposed considering both normal and faulted operations. Therefore, the proposed strategy has a two layer structure. In upper layer, the real power which can be extracted from number of PEVs in parking lots is calculated through detailed model of energy storage system considering temperature of the battery packs. Then, the computed power is sent to the lower

layer. In the lower layer, the proposed energy management strategy is implemented. In doing so, multi operators are responsible to control the network. Also, since contingency faults may occur in the network, parametric multi-objective function is used to address both faulted and normal operations. In addition, the proposed energy management strategy has to consider some physical limitations and constrains of the grid.

The remainder of this work is organized as follows: the under studied system is defined in section 2, furthermore detailed model for energy storage of PEV is presented in this section. Proposed energy management strategy presented in section 4. Simulation results from effectiveness of the proposed method on the scheduling of the MMG systems are presented in sections 4, finally section 5 concludes this paper.

2. MMG system under study

A brief structure of the MMG system under study is shown in Figure 2. The MMG system considered in this investigation includes several separate MGs and distribution network. From the energy management viewpoint, a decentralized structure is considered, therefore, all MGs are managed by their operator separately and the distribution network operator does not have the right to control the distributed generations (DGs) which are located in MGs areas. Each MG contains PEVs, DG units, and different type of loads. In order to gain benefits, operators can control the PEVs to charge them when electricity price is cheap and use their energy when electricity price is expensive.

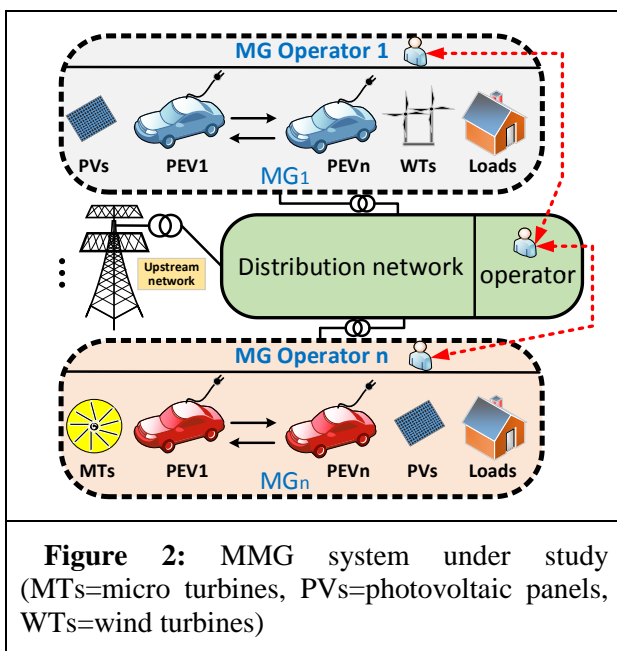

Figure 2: MMG system under study (MTs=micro turbines, PVs=photovoltaic panels, WTs=wind turbines)

All MGs are connected with the distribution network through point of common coupling and

related transformers. Also, distribution network is connected to the upstream network and can purchase power from it.

2.1. PEV energy storage model

There are many lithium-ion battery cells for PEV application, which each of them has its strengths and limitations. In this context, charging and the discharge rate and cells temperature are the main external characteristic that directly affects the battery performance. Therefore, for studies related to the PEV application, taking the battery safety and battery health into account, an appropriate battery model is generally needed. In the recent years, numerous battery models have been presented in the articles to model the electrical and thermal behavior of the battery storage systems and also to predict the SOC and internal characteristics (e.g. internal resistance and etc.) [31-33]. In this regard, one of the efficient model is the linear model [33] which the modified version of this model with consideration of the battery temperature is shown in Figure 3. The present model subtract/sum the voltage drop and the open-circuit voltage at a determined SOC to simplify the calculation of the cell voltage; the basic equations of this model are formulated as (1) and (2) for the charge and discharge process, respectively. It must be notice that, temperature dependence is an important characteristic that must be taken into account to validate the model at any uncertain temperature.

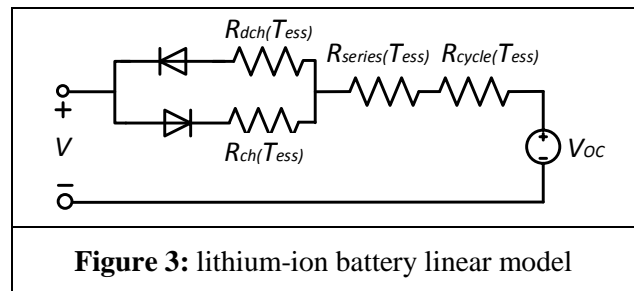

Figure 3: lithium-ion battery linear model

$$V_t = V_{oc}(T_{ess}) + i_{ch}(R_{ch}(T_{ess}) + R_{cycle}(T_{ess}) + R_{series}(T_{ess})) \quad \text{charging mode}, \forall t, T_{ess} \quad (1)$$

$$V_t = V_{oc}(T_{ess}) + i_{dch}(R_{dch}(T_{ess}) + R_{cycle}(T_{ess}) + R_{series}(T_{ess})) \quad \text{discharging mode}, \forall t, T_{ess} \quad (2)$$

Where, t is the discrete index for time, i_{dch} and i_c are the discharge and charge current, respectively; v_t is represents voltage variable, R_{cycle} represents cycling resistance, R_{series} is series resistance, R_{ch} and R_{dch} are the resistances for charging and discharging modes, respectively.

Along with the ease of implementation and simplicity of the model presented in Figure 5, it is suggested in applications where the current is basically temperature dependent. The relationship between the V_{oc} and SOC for any PEVs regardless the size of battery pack can be obtained by mapping the experimental results (average charging and discharging voltages) with the SOC.

Meanwhile, considering charging voltage and the internal impedance, the output current of the battery pack can be determined. To enhance the accuracy of the simulation, the improved model of Coulomb-counting method [34] by considering the SOC loss, temperature and current efficiency is proposed in this study to calculate the SOC. In addition, the age of the battery pack and self-discharge are considered too. The basic equations of the proposed improved Coulomb-counting model are formulated in (3) and (4).

$$SOC(t) = SOC(t-1) + \left(\frac{1}{C_T} \int_{t_0}^t |I| dt\right) \quad (3)$$

$-L_{age} - L_T - L_{s-dch}$ during charging

$$SOC(t) = SOC(t-1) - \left(\frac{1}{C_T} \int_0^t |I| dt\right) \quad (4)$$

$-L_{age} - L_T - L_{s-dch}$ during discharging

It should be noted that, an accurate measurement of battery current (I) and also the initial value of SOC (SOC_{t-1}) are needed for this method. Where, C_T represents the total capacity that the battery can hold at a certain temperature, L_{age} is the SOC loss to represent the battery aging, L_{s-dch} is the SOC loss to represent the self-discharge and L_T is the SOC loss of temperature.

For both charging and discharging modes, the sum of the values of $R_{ch} / R_{dch} + R_{cycle} + R_{series}$ can be found with (5) and (6) using least square estimation [35] and the data available for any type of lithium-ion battery pack.

$$V = \begin{bmatrix} V_1 - V_{oc}(SOC_1, T_{ess}) \\ V_2 - V_{oc}(SOC_2, T_{ess}) \\ \vdots \\ V_t - V_{oc}(SOC_t, T_{ess}) \end{bmatrix} = \begin{bmatrix} i_1^{ch/dch} \\ i_2^{ch/dch} \\ \vdots \\ i_t^{ch/dch} \end{bmatrix} \times (R_{ch} / R_{dch} + R_{cycle} + R_{series}) \quad (5)$$

$$(R_{ch} / R_{dch} + R_{cycle} + R_{series}) = \left(\begin{bmatrix} i_1^{ch/dch} \\ i_2^{ch/dch} \\ \vdots \\ i_t^{ch/dch} \end{bmatrix}^{-T} \times \begin{bmatrix} i_1^{ch/dch} \\ i_2^{ch/dch} \\ \vdots \\ i_t^{ch/dch} \end{bmatrix} \right)^{-1} \times \begin{bmatrix} i_1^{ch/dch} \\ i_2^{ch/dch} \\ \vdots \\ i_t^{ch/dch} \end{bmatrix} \times \begin{bmatrix} V_1 - V_{oc}(SOC_1, T_{ess}) \\ V_2 - V_{oc}(SOC_2, T_{ess}) \\ \vdots \\ V_t - V_{oc}(SOC_t, T_{ess}) \end{bmatrix} \quad (6)$$

The thermal model of battery which initially developed at national renewable energy laboratory (NREL) is used [36] in the present investigation aiming to evaluate the battery pack temperature. For this propose, Figure 4 illustrates the configuration of battery thermal design and analysis. Quoting from Ref. [37], the related equations of this model are as follow:

$$H_d = \frac{T_{ess} - T_{air}}{R_{eff}} \quad (7)$$

$$R_{eff} = \frac{1}{h\sigma} + \frac{t}{k\sigma} \quad (8)$$

$$h = \begin{cases} a \left(\frac{m / \rho A}{5} \right)^b & T_{ess} > T_{ess-set} \\ 4 & T_{ess} < T_{ess-set} \end{cases} \quad (9)$$

$$T_s = T_{amb} + \frac{0.5H_d}{r_{air} C_{p,air}} \quad (10)$$

$$P_{l,ess} = \eta_c (R_{ch} / R_{dch} + R_{cycle} + R_{series}) I^2 \quad (11)$$

$$T_{ess} = \int_0^t \frac{H_d - P_{l,ess}}{m_{Batt} C_{p,Batt}} dt \quad (12)$$

Where H_d is represents the heat dissipate, T_s is environment temperature surround the battery pack ($^{\circ}C$), T_{ess} is battery pack temperature ($^{\circ}C$), R_{eff} is effective thermal resistance, T_{amb} is ambient temperature ($^{\circ}C$), r_{air} represents the air flow rate, $C_{p,air}$ is air heat capacity, m_{Batt} is the mass of battery pack, C_{Batt} represents the heat capacity of battery, h is the coefficient of heat transfer, K is the coefficient of heat conductivity, a, b are the geometry indexes for battery pack, A is area of battery pack (m^2), ρ represents the air density, t, σ are the related parameters to represent different battery pack, P_r is request power of battery pack (w), $P_{l,ess}$ is the power loss of battery pack (w) and η_c is columbic efficiency.

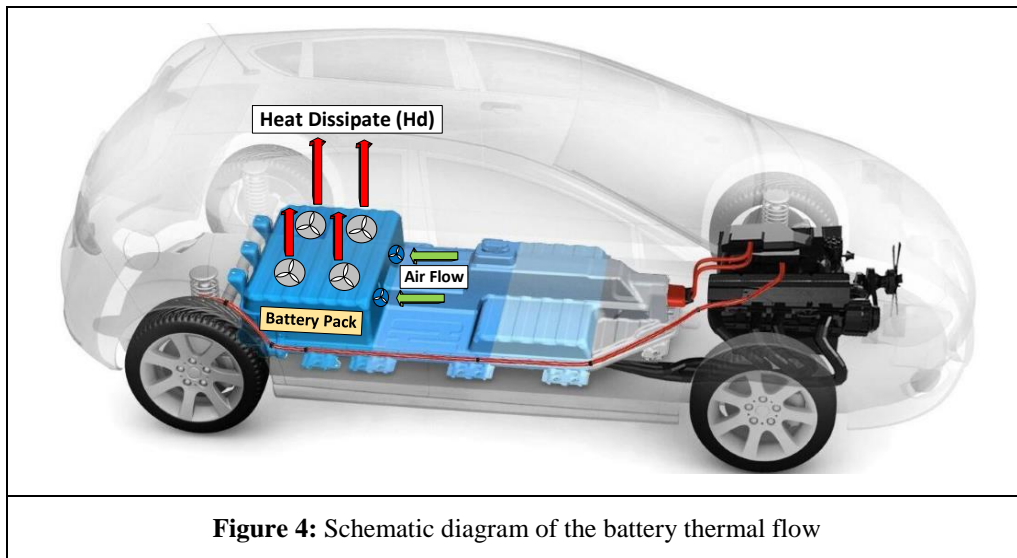

Figure 4: Schematic diagram of the battery thermal flow

In this situation, temperature limit for battery pack is:

$$T_{ess} \leq T_{ess}^{max} \quad (13)$$

With consideration of the minimum SOC and a predetermined limit (a), the discharging power must be limited depending on the exact amount of SOC. Considering λ_w as a set of periods where the PEV $w \in W$ is on the charging mode, the charging and discharging power are bounded with the equations (14)-(16).

$$0 \leq P_{PEV}(t,w) \leq \bar{P}_{PEV}(w) \times x_{PEV}(t,w), \quad \text{charging mode}, \forall t \in \lambda_w \quad (14)$$

$$0 \leq P_{PEV}(t,w) \leq \bar{P}_{PEV}(w) \times (1 - x_{PEV}(t,w)), \quad \text{discharging mode}, \forall t \in \lambda_w \quad (15)$$

$$P_{PEV}(t,w) \leq \frac{\bar{P}_{PEV}(w)}{a} \times SOC(t-1,w), \quad \text{discharging mode}, \forall t \in \lambda_w \quad (16)$$

Where $P_{PEV}(t,w)$ is charging/discharging rate of the PEV [kW], $\bar{P}_{PEV}(w)$ represents the highest value of instantaneous power for the PEV [kW], $x_{PEV}(t,w)$ is power flow direction in the PEV battery, which model as binary variables to show the status (charging/discharging modes) of the battery of the corresponding PEV:

$$\begin{cases} x_{PEV}(t,w) = 1, \text{ if the PEV } w \in W \\ \quad \text{is charging in period } t \in \lambda_w \\ x_{PEV}(t,w) = 0, \text{ otherwise} \end{cases} \quad (17)$$

The energy demand that will be used by the vehicle in the periods $t \in T$ can be defined as the following equation.

$$P_{EV}(t,w) = \begin{cases} \left(\beta P_{PEV, ch}(t,w) - \frac{P_{PEV, dis}(t,w)}{\eta} \right) \Delta t, \text{ if } t \in \lambda_w \\ R_{PEV}(w), \text{ if } t \in T \end{cases} \quad (18)$$

Where, $R_{PEV}(w)$ represents the energy required by the non-connected vehicle, $P_{PEV, ch}(t,w)$ is the charging rate of the PEV [kW], $P_{PEV, dis}(t,w)$ is the discharging rate of the PEV [kW], β is the charge efficiency [%], η represents the discharge efficiency [%] and Δt is the duration of the time intervals.

Then, the state of charge must be limited by:

$$SOC_{min}(t,w) \leq SOC(t,w) \leq SOC_{max}(t,w) \quad (19)$$

Where, $SOC_{max}(t,w)$ is the maximum SOC for the PEV and time interval [%] and $SOC_{min}(t,w)$ is the minimum SOC for each PEV and time interval [%].

Also, Eq. (20) ensures that the batteries cannot charge and discharge simultaneously. On the other hand, since, battery life depends on the number of cycles of the charging/discharging process, the frequency of discharge and charge conversion must be limited as Eq. (21).

$$\kappa_{EV}^{ch}(t) + \kappa_{FBESS/EV}^{dch}(t) \leq 1 \quad \forall t \quad (20)$$

$$\left| \kappa_{EV}^{ch}(t) - \kappa_{EV}^{ch}(t-1) \right| \leq N_{EV}^{state} \quad \forall t \quad (21)$$

3. Proposed energy management strategy

In the power grids the probability of fault occurrence is not out of expectation. When the contingency event occurs in the MMG system, each MG will experience one of the following operation modes: 1) Faulted operation: in this mode, protective elements might disconnect some faulted sections of MGs from the distribution network. In this situation, MGs might be able to continue supplying loads in forced island mode; 2) Normal operation: the customers within these modes would not be interrupted and the operators have to determine grid-connected or optional island modes.

Considering the above mentioned facts, in order to effectively deal with uncertainties of unpredictable fault occurrences, the contingency based energy management for MMG system is presented in this section. In the proposed energy management, optimization of power flow control and economic dispatch of PEVs are taken into consideration and a two-layer energy management strategy is proposed to perform the optimal operation of PEVs in both faulted and normal operation modes. In this context, it is assumed that the size of all dispatchable DGs (MTs) and renewable resources (PVs and WTs) in the system are already optimized and installed before the scheduling of PEVs. A flowchart of the proposed energy management strategy for optimization of power flow control and economic dispatch of PEVs in the MMG systems is shown in Figure 5. In the proposed cooperative optimization model, at first, data from PEVs, DGs, distribution network and different type of demands are collected and then capacity management and economic dispatch of PEVs are achieved under cooperative decentralized operation mode.

3.1. Problem formulation

In this section, the parametric problem formulation is presented to address both faulted and normal operation. In this situation, the objective functions for MGs and distribution network are formulated separately in the following sub-sections:

3.1.1. Problem formulation for MGs

MGs in each side of the system try to solve their own grid problems taking into account the probability of equipment failure. Consequently, minimize the deviation of production and consumption (OF₁) using storage capacity of PEVs and minimize the overall operation cost (OF₂) are the intended objective functions that

have to be optimized simultaneously with some network constraints.

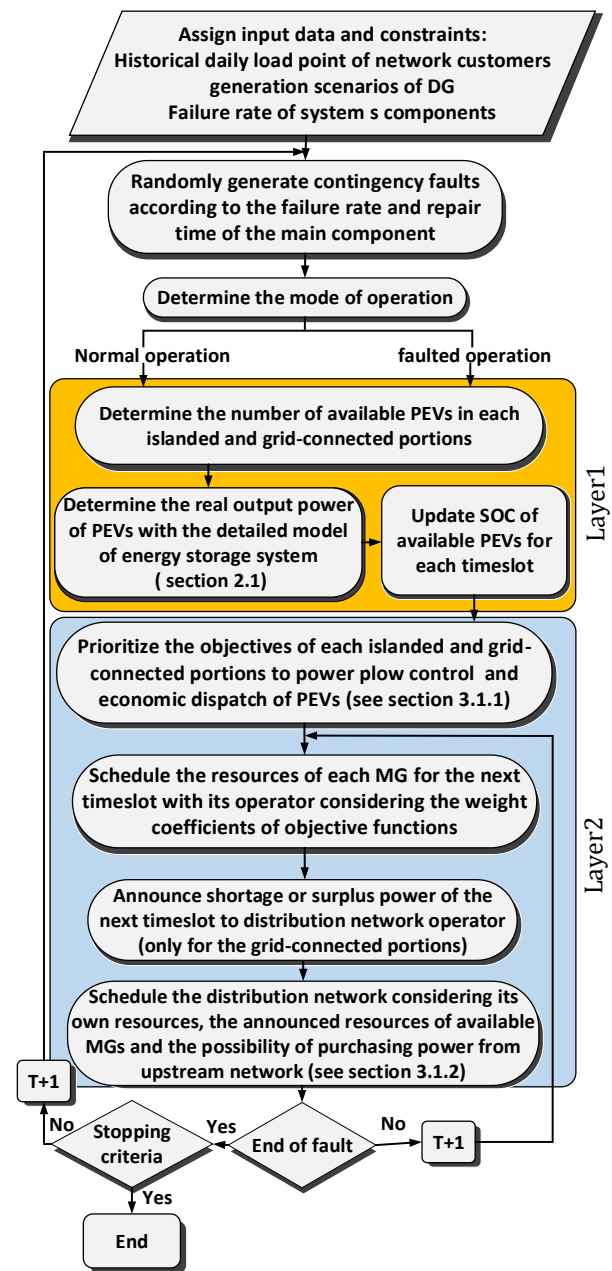

Figure 5: Schematic diagram of the proposed energy management

The aim is to solve these two different objective functions into one using the parametric coefficients. Therefore, the intended objective function for MGs operation is formulated as follows:

$$\text{Min}\{F_t\} = \gamma_{i1}F_1 + \gamma_{i2}F_2, \gamma_{i1} \& \gamma_{i2} \in [0 \leftarrow \downarrow \rightarrow 1] \quad (22)$$

$$F_1 : \text{Min} \sum_{t=1}^{n_t} \{ (\sum_{j=1}^{n_{ev}} S_{PEV}^{j,m}(t) P_{PEV}^{j,m}(t) A_{PEV}^{j,m}(t)) + (\sum_{j=1}^{n_{DG}} P_{DG, MG}^{j,m}(t) A_{DG, MG}^{j,m}(t)) - \sum_{j=1}^{n_{cus}} (P_{cus, MG}^{j,m}(t)) \} \quad (23)$$

$$\begin{aligned}
 F_2 : \text{Min} \sum_{m \in M} \sum_{t=1}^{n_t} \{ & (C_{PEV}(t) \sum_{j=1}^{n_{ev}} S_{PEV}^{j,m}(t) P_{PEV}^{j,m}(t) A_{PEV}^{j,m}(t)) \\
 & + (C_{DG}(t) \sum_{j=1}^{n_{DG}} P_{DG}^{j,m}(t) A_{DG}^{j,m}(t)) \\
 & + (C_{Ex}^m(t) \beta_{Ex}^m(t) P_{Ex}^m(t) A_{Ex}^m(t)) \}
 \end{aligned} \tag{24}$$

where, A is a binary variable which is indicate availability (1) and unavailability (0) of the units (PEVs or DGs), C_{DG} is operation cost of DGs, C_{DG} is charging or discharging cost of PEVs, C_{Ex} is the trading price between distribution network and MGs and P is the power in level of each unit; e.g. $P_{cus, MG}$ is consumption energy with customer of MGs In (22), γ_{i1} and γ_{i2} are weight coefficients for F_1 and F_2 , respectively; in order to privileged some objectives than others, these weight coefficients are adjusted according to importance degree of objective functions considering the system operation modes. Consequently, regarding system status, the weights of the functions are considered: (1, 0), (0.35, 0.65) and (0, 1) for partly islanded portions (related to the faults), optional islanded mode and grid-connected mode, respectively. These weights were extracted with sensitivity analysis to rank functions based on their contributive effects.

The overall constraints of each MG operation are considered as follows:

• **Power balance constraints:**

For each MGs, the energy balance must be fulfilled. In this situations, the balance of energy is considered as (25).

$$\begin{aligned}
 \sum_{j=1}^{n_{ev}} S_{PEV}^{j,m}(t) P_{PEV}^{j,m}(t) + \sum_{j=1}^{n_{DG}} P_{DG, MGs}^{j,m}(t) + \\
 + \sum_{j=1}^{n_e} \beta_{Ex}^m(t) P_{Ex}^{j,m}(t) = \sum_{j=1}^{n_{Cu}} P_{cus, MG}^{j,m}(t), \forall j, m, t
 \end{aligned} \tag{25}$$

• **Limit of power exchanged between distribution network and MGs:**

The constraint of exchanging power between distribution network and MGs is implemented as:

$$-P_{Ex}^{m, \max}(t) \leq P_{Ex}^m(t) \leq P_{Ex}^{m, \max}(t), \forall m, t \tag{26}$$

• **Generation limits on DG Units:**

For each MGs, in each timeslot the power output of DGs ($P / Q_{DG, MGs}$) must be limited as:

$$P_{DG, MGs}^{j, m, \min}(t) \leq P_{DG, MGs}^{j, m}(t) \leq P_{DG, MGs}^{j, m, \max}(t), \forall j, m, t \tag{27}$$

$$Q_{DG, MGs}^{j, m, \min}(t) \leq Q_{DG, MGs}^{j, m}(t) \leq Q_{DG, MGs}^{j, m, \max}(t), \forall j, m, t \tag{28}$$

• **Power flow constraints:**

The Newton-Raphson AC power flow method is used in our problem formulation [38], and based on its outputs, the inequality voltage magnitude is limited in a predetermined bound as follows:

$$V_i^{\min}(t) \leq V_i(t) \leq V_i^{\max}(t), \forall i, t \tag{29}$$

3.1.2. Problem formulation for distribution network

The operation objective of distribution network is formulated with the goal of minimization of the overall cost for each operation timeslot. In this situation, the operation costs of distribution network are: power exchange cost between each MGs and distribution network ($C_{Ex}(t) \times P_{Ex}(t)$), power exchange cost between distribution network and upstream network ($C_{UN}(t) \times P_{UN}(t)$) and the cost of power generation with DGs. Consequently, the objective function for operation of distribution network is considered as follows:

$$\begin{aligned}
 F : \text{Min} \sum_{t=1}^{n_t} \{ & (\sum_{k=1}^{n_{MG}} C_{Ex}^k(t) \beta_{Ex}^K(t) P_{Ex}^K(t) A_{Ex}^k(t)) \\
 & + (\sum_{k=1}^{n_{DG}} C_{DG, DN}^k(t) P_{DG, DN}^k(t) A_{DG, DN}^k(t)) \\
 & + (C_{UN}(t) P_{UN}(t) A_{UN}(t)) \}
 \end{aligned} \tag{30}$$

Constraints for operation of distribution network are considered as follows:

• **Power balance constraints:**

For distribution network at each timeslot, the balance of energy is considered as:

$$\begin{aligned}
 \sum_{k=1}^{n_{DG}} P_{DG, DN}^k(t) + \sum_{k=1}^{n_{MG}} \beta_{Ex}^K(t) P_{Ex}^k(t) + P_{UN}(t) \\
 = \sum_{k=1}^{n_{Cu}} P_{Cus, DN}^k(t) \quad \forall k, t
 \end{aligned} \tag{31}$$

• **Limit of power exchanged between distribution network and upstream network:**

The power transferred between distribution network and upstream network (P/Q_{UN}) must be limited as (32) and (33).

$$-P_{UN}^{\max}(t) \leq P_{UN}(t) \leq P_{UN}^{\max}(t) \quad \forall t \tag{32}$$

$$-Q_{UN}^{\max}(t) \leq Q_{UN}(t) \leq Q_{UN}^{\max}(t) \quad \forall t \quad (33)$$

- **Generation limits on DG Units:** same as (27 and 28)
- **Limit of power exchanged between MGs and distribution network:** same as (26)
- **Voltage magnitude limits:** same as (29)

4. Simulation results

From the detailed battery model presented in section 2.1, the battery cell temperature has a direct relationship with the charging/discharging current. From this point of view, with consideration of 8 hour discharging mode, battery SOC and discharging current for 22kWh battery pack of one kind of PEV [39] are simulated and shown in Figure 6 and 7, respectively; also, a meaningful relationship between discharging current of Figure 7 and battery pack temperature is shown in Figure 8. From this figure, it can demonstrate that the temperature is raising slope increases with increase in discharging times.

The internal resistance increase rate as a function of temperature (in constant SOC) is also shown in Figure 9. It is clear that, there is the direct relationship between internal resistance and energy losses, also, as illustrated in Figure 9, there is the direct relationship between internal resistance and temperature, especially at the late stage of battery life. This means that in the both charging and discharging cycle progresses, thermal stress will affect the battery pack, and this causes the battery pack to show different performance at different temperatures. Therefore, in power systems, excessive use of PEVs for storage applications, will lead to an accelerated aging phenomena for Lithium-ion battery in such vehicle. Thus, it can be concluded that, detailed model of PEV energy storage system is necessary for V2G applications in power grids.

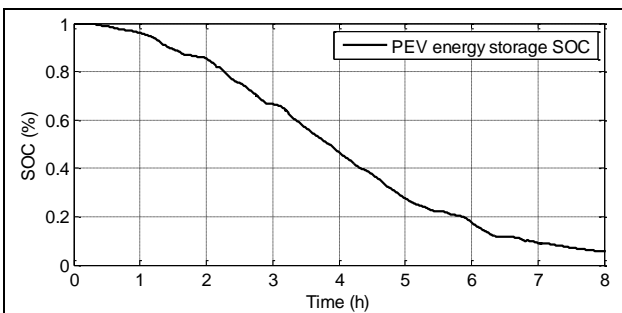

Figure 6: PEV battery pack SOC under 8 hour discharging mode

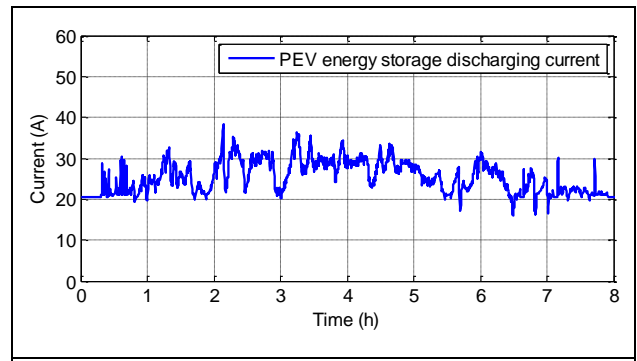

Figure 7: PEV battery pack current under 8 hour discharging mode

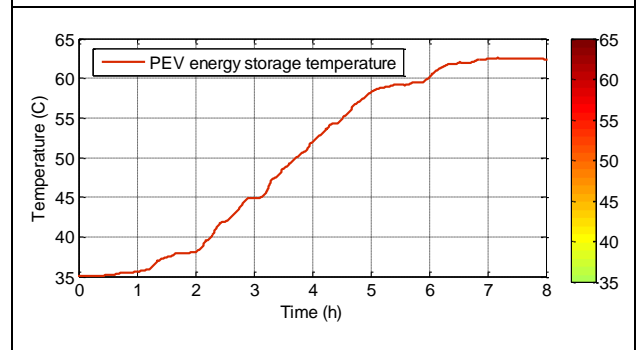

Figure 8: PEV battery pack temperature under 8 hour discharging mode

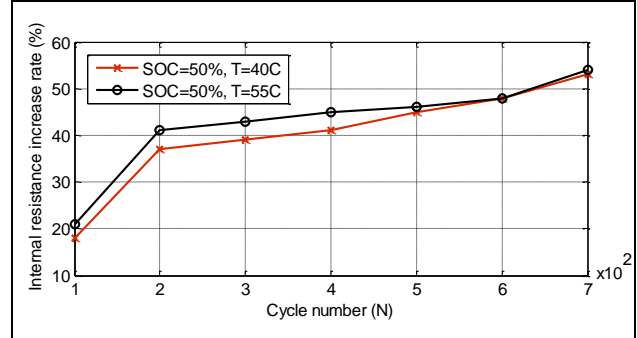

Figure 9: PEV battery pack internal resistance rate curve with temperature variation

4.1. Case study

In order to demonstrate the performance of the proposed energy management strategy along with the proposed detailed model of PEVs energy storage system, additional simulations were made in modified version of reliability test system. In this situation, the feeder F4 in IEEE RBTS (Bus 6) system [46] is taken as the foundation of the grid structure in this paper, and make proper alterations to it (see Figure 10); detail load data of this grid is shown in Table 1. Also, the information of intended resources and detailed information of the parking lots are shown in Table 2 and 3, respectively.

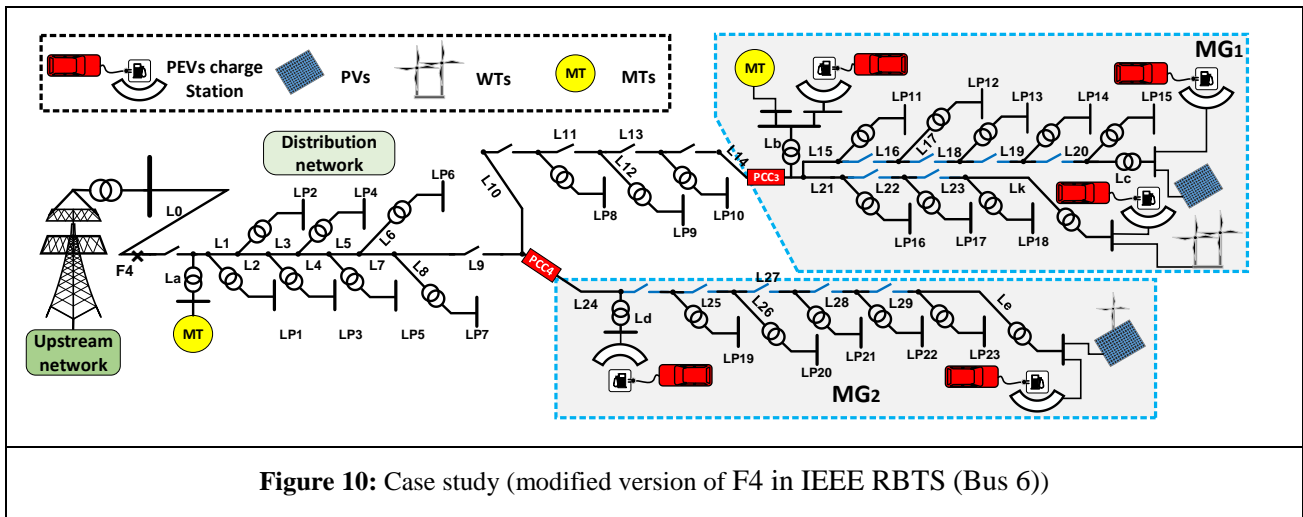

Figure 10: Case study (modified version of F4 in IEEE RBTS (Bus 6))

Feeder F4 at bus 6 is a rural grid which contains of agricultural and residential customers. This modified version is called MMG system which has two separate MGs and distribution network. The basic parameters for the test system can be found in [40]. Reliability data of DG units is adopted from [41]. Also, repair time and failure rate of the transformer and distribution line are given from [42]; related values for upstream network are borrowed from [26]. Motivated by the above motioned information, the contingency event are considered in each timeslot via random sampling method [43]. The input wind speed and solar irradiation data are given from [44]. Also, tariffs for buying and selling energy are given from [45]. The daily profile for the agricultural and residential loads is adopted from [46].

Table 1: Detail load data of MMG system under study

Units	Load points	Customer type	Peak load (MW)	Number of Customers
Distribution network	1, 6	R	0.2964	147
	2	R	0.3229	126
	3	A	0.6517	1
	4	A	0.6860	1
	5	R	0.3698	132
	7	A	0.7965	1
	8	R	0.2776	79
	9	A	0.7375	1
	10	R	0.2831	76
	MG ₁	11,16	R	0.2776
14,17		R	0.2831	76
18		A	0.6517	1
12		A	0.5025	1
13		A	0.7375	1
MG ₂	15	A	0.7965	1
	19	R	0.2776	79
	20	A	0.5025	1
	21	R	0.2831	76
	22	A	0.6517	1
23	A	0.6860	1	

Table 2: Information of intended resources in case study

Units	Type	Max Capacity (kW)
Distribution network	MTs	1800
	WTs	1300
MG ₁	PVs	700
	WTs	1250
MG ₂	PVs	800

Table 3: Detailed information of the parking lots for each MG

Area	Maximum number of PEV per each parking lot	Available Time	Primary SOC (%)	
			Percentage	Range
MG ₁	60	9:00-14:00 & 17:00-24:00	40%	SOC < 40
			20%	40 ≤ SOC < 70
			20%	70 ≤ SOC < 90
			20%	90 ≤ SOC < 100
MG ₂	80	00:00-24:00	60%	SOC < 50
			25%	50 ≤ SOC < 80
			10%	80 ≤ SOC < 90
			5%	90 ≤ SOC < 100

To demonstrate the performance of the proposed parametric objective function for energy management of both faulted and normal conditions, the following three cases were simulated separately.

Case 1: uncoordinated energy management of MMG systems with no power transfer between sub-sections.

Case 2: Optimal energy management of MMG systems for power flow control and economic dispatch of PEVs based on the fixed weighted multi-objective function [0.5, 0.5].

Case 3: Optimal energy management of MMG systems for power flow control and economic dispatch of PEVs based on the proposed parametric multi-objective function.

According to the proposed parametric multi-objective function, the stored energy in each PEVs energy storages has been mostly consumed during emergencies in order to reduce outage times. On the other hand the economic dispatch of all resources (e.g. PEVs and DGs) is the primary goal of the operators during normal operation. Therefore, proper control on power capacity of PEVs energy storages might benefit power system reliability greatly. From this point of view, for one day of operation, considering failure rate of the component and outcome of sampling method, two fault occurrence were considered simultaneously for L0 and L10 (with repair time 8 hour); then reliability indices of MMG system in case 1 to case 3 have been calculated and the results are provided in Figure 11 and 12. As a note, energy not supplied (ENS) represents the total energy not supplied for the total number of customers and system average interruption duration index (SAIDI) is the average outage duration for each customer serve [47].

It can be observed that case 3 has the best overall reliability level compared with case 1 and 2. This is due to the fact that considering the parametric objective function, the stored energy in each PEVs can be utilized in more contingencies. Therefore, by proper control on power capacity of PEVs energy storages and appropriate use of other resources, it is possible to effectively improve the reliability level of the customers with poor reliability conditions, particularly in distribution networks with radial configuration. It must be notice that for each time slot the available power of each PEVs is extracted through detailed model of section 2.1 and information of Table 3.

Therefore, considering the simulation results, it can be concluded that integration of PEVs in MMG networks along with the appropriate energy management not only improves system efficiency, but also will enhance the system reliability against unpredictable contingency faults. However, it is evident that the degree of improvement is mainly dependent on the number of PEVs, configuration of the power network as well as the location of parking lots.

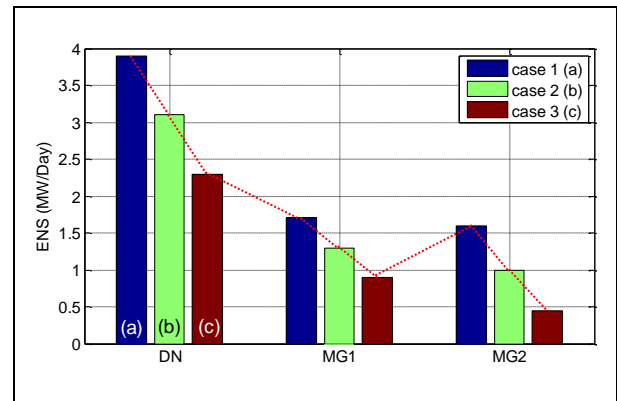

Figure 11: ENS index of each sub-section

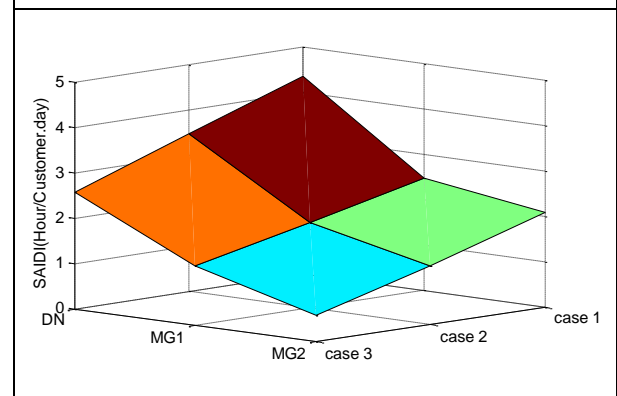

Figure 12: SAIDI index of each sub-section

5. Conclusions

In this paper, a detailed model for energy storage system of PEVs considering the cooling system is presented. Then, a novel hierarchical energy management strategy for scheduling of PEVs in a MMG is proposed considering both normal and faulted operations. In doing so, parametric multi-objective function is used to address both faulted and normal operations. The simulation results indicate that, considering proper energy management of energy storage systems of PEVs has significant influence on energy scheduling of MMG systems.

References

- [1] S. Taggart, G. James, Z. Y. Dong, C. Russell, The future of renewables linked by a transnational Asian grid, Proceedings of the IEEE., Vol.100, No.2, (2012), pp.348-359.
- [2] Z. Dong, K. P. Wong, K. Meng, F. Luo, F. Yao, J. Zhao, Wind power impact on system operations and planning, IEEE Power and Energy Society General Meeting, Minneapolis, USA, (2010), pp.1-5.

- [3] Y. Ding, C. Singh, and L. Goel, Short-Term and Medium-Term Reliability Evaluation for Power Systems with High Penetration of Wind Power, *IEEE Transactions on Sustainable Energy*, Vol.5, No.3, (2014), pp.896-906.
- [4] Y. Ding, L. Cheng, Y. Zhang, Y. Xue, Operational Reliability Evaluation of Restructured Power Systems with Wind Power Penetration utilizing Reliability Network Equivalent and Time-sequential Simulation Approaches, *Journal of Modern Power Systems and Clean Energy*, Vol.2, (2014), pp.329-340.
- [5] M. Kesler, M. C. Kisacikoglu, L. M. Tolbert, Vehicle-to-grid reactive power operation using plug-in electric vehicle bidirectional offboard charger, *IEEE Transactions on Industrial Electronics*, Vol.61, No.12, (2014), pp. 6778-6784.
- [6] M. Yilmaz, et. al., "Review of the Impact of Vehicle-to-Grid Technologies on Distribution Systems and Utility Interfaces," *IEEE Transaction on Power Electronics*, Vol.28, No.12, (2013), pp.5673-5689.
- [7] X. Hu, Y. Zou, Y. Yang, Greener plug-in hybrid electric vehicles incorporating renewable energy and rapid system optimization, *Energy*, Vol. 111, (2016), pp.971–980.
- [8] X. Wu, X. Hu, S. Moura, X. Yin, V. Pickert, Stochastic control of smart home energy management with plug-in electric vehicle battery energy storage and photovoltaic array, *Journal of Power Sources*, Vol.333, (2016), pp.203-212.
- [9] R. Yu, W. Zhong, S. Xie, C. Yuen, S. Gjessing, and Y. Zhang, Balancing power demand through EV mobility in vehicle-to-grid mobile energy networks, *IEEE Transaction Industrial Informatics*, Vol.12, No.1, (2016), pp.79-90.
- [10] W. Zhong, R. Yu, S. Xie, Y. Zhang, D. K. Y. Yau, On stability and robustness of demand response in V2G mobile energy networks, *IEEE Transaction on Smart Grid*, Vol.9, No.4, (2016), pp. 3203- 3212.
- [11] W. Shi and W. W. S. Wong, Real-time vehicle-to-grid control algorithm under price uncertainty," *IEEE International Conference on Smart Grid Communications*, (2011), pp.261-266.
- [12] S. Deilami, A. S. Masoum, P. S. Moses, M. A. S. Masoum, Realtime coordination of plug-in electric vehicle charging in smart grids to minimize power losses and improve voltage profile, *IEEE Transaction on Smart Grid*, Vol.2, No.3, (2011), pp.456-467.
- [13] C. Chen and S. Duan, Optimal integration of plug-in hybrid electric vehicles in microgrids, *IEEE Transaction Industrial Informatics*, Vol. 0, No.3, (2014), pp.1917-1926.
- [14] S. Shao et al, Impact of TOU rates on distribution load shapes in a smart grid with PHEV penetration, *Transmission and distribution conference and exposition*, (2010), pp.1-6.
- [15] K. Qian et al, Modeling of load demand due to EV battery charging in distribution systems, *IEEE Transaction on Power System*, Vol.26, No.2, (2011), pp.802-810.
- [16] M. Montazeri-Gh, M. Khasheinejad, Z. Pourbafarani, Model Based Design approach for Implementation of PHEV Energy Management, *International Journal of Automotive Engineering*, Vol. 9, No. 2, (2019), pp.2958-2965.
- [17] K. Clement et al, The impact of charging plug-in hybrid electric vehicles on a residential distribution grid, *IEEE Transaction Power System*, Vol.25, No.1, (2010), pp.371-380.
- [18] L. Tae-Kyung, Z. Bareket, T. Gordon, Z. S. Filipi, Stochastic modeling for studies of real-world PHEV usage: Driving schedule and daily temporal distributions, *IEEE Transaction Vehicular Technology*, Vol.61, No.4, (2012), pp.1493–1502.
- [19] P. Jarventausta, S. Repo, A. Rautiainen, J. Partanen, Smart grid power system control in distributed generation environment, *Annual Reviews in Control*, Vol.4, No.2, (2010), pp.277-286.
- [20] P. Grahn, J. Munkhammar, J. Widen, K. Alvehag, L. Soder, PHEV home-charging model based on residential activity patterns, *IEEE Transaction on Power System*, Vol.28, No.3, (2013), pp.2507-2515.
- [21] J. Pahasa, I. Ngamroo, PHEVs Bidirectional Charging/Discharging and SOC Control for Microgrid Frequency Stabilization Using Multiple MPC, *IEEE Transactions on Smart Grid*, Vol.6, No.2, (2015), pp.526-533.
- [22] X. Wang, Q. Liang, Energy Management Strategy for Plug-In Hybrid Electric Vehicles via Bidirectional Vehicle-to-Grid, *IEEE Systems Journal*, Vol.11, No.3, (2015), pp.1789-1798.
- [23] Y. Xiang, J. Tan, and L. Wang, A Particle Swarm Optimization Based Control Strategy for Plug-in Hybrid Electric Vehicles at Residential Networks Level, *IEEE PES T&D Conference and Exposition*, (2014), pp. 1-5.

- [24] S. J. Chen, T. S. Zhan, C. H. Huang, J. L. Chen, C. H. Lin, Nontechnical Loss and Outage Detection Using Fractional-Order Self-Synchronization Error-Based Fuzzy Petri Nets in Micro-Distribution Systems, *IEEE Transactions on Smart Grid*, Vol.6, No.1, (2015), pp.411-420.
- [25] H. Farzin, M. Fotuhi-Firuzabad, M. Moeini-Aghaie, Reliability Studies of Modern Distribution Systems Integrated with Renewable Generation and Parking Lots, *IEEE Transactions on Sustainable Energy*, Vol.8, No.1, (2017), pp.431-440.
- [26] H. Farzin, M. Fotuhi-Firuzabad, M. Moeini-Aghaie, Role of Outage Management Strategy in Reliability Performance of Multi-Microgrid Distribution Systems, *IEEE Transactions on Power Systems*, Vol.33, No.3, (2018), pp.2359-2369.
- [27] Z. Wang, B. Chen, J. Wang, J. Kim, Decentralized energy management system for networked microgrids in grid-connected and islanded modes, *IEEE Transactions on Smart Grid*, Vol.7, No.2, (2016), pp.1097-1105.
- [28] A. Hausmann and C. Depcik, Expanding the Peukert equation for battery capacity modeling through inclusion of a temperature dependency, *Journal of Power Sources*, Vol.235, No.1, (2013), pp.148-158.
- [29] P. Rahimirad, M.M. Tehrani, M. Dahmardeh, Battery life investigation of a hybrid energy management system considering battery temperature effect, *International Journal of Automotive Engineering*, Vol. 9, No. 2, (2019), pp. 2966-2976.
- [30] C. Zhu, X. Li, L. Song and L. Xiang, Development of a theoretically based thermal model for lithium ion battery pack, *Journal of Power Sources*, Vol.223, (2013), pp.155-164.
- [31] M. Nikdel et al., "Various battery models for various simulation studies and applications," *Renewable and Sustainable Energy Reviews*, vol. 32, pp. 477-485, 2014.
- [32] Y. S. Ranjbaran, M.H. Shojaeefard, G.R. Molaeimanesh, Thermal behavior of a commercial prismatic Lithium-ion battery cell applied in electric vehicles, *International Journal of Automotive Engineering*, Vol. 8, No. 2, (2018), pp. 2700-2708.
- [33] Y. H. Kim and H.D. Ha, Design of interface circuits with electrical battery models, *IEEE Transactions on Industrial Electronics*, Vol.44, No.1, (2016), pp.81-86.
- [34] K. S. Ng, C.-S. Moo, Y. P. Chen, Y. C. Hsieh, Enhanced coulomb counting method for estimating state-of-charge and state-of-health of lithium-ion batteries, *Applied energy*, Vol.86, No.9, (2009), pp.1506-1511.
- [35] A. A. Hussein, I. Batarseh "An overview of generic battery models", *IEEE Power and Energy Society General Meeting*, (2011), pp.1-6.
- [36] A. A. Pesaran, A. Vlahinos, S. D. Burch, Thermal performance of EV and HEV battery modules and packs, in *Proceedings of the 14th Internal Electric Vehicle Symposium*, (1977), pp.7803-6545.
- [37] Z. Rao and S. Wang, A review of power battery thermal energy management, *Journal of Renewable and Sustainable Energy Reviews*, Vol.15, (2011), pp.4554-4571.
- [38] Glover, J. D., Sarma, M. S., Overbye, T. J., *Power System Analysis and Design*, Fifth Edition, Global Engineering, 2011.
- [39] A. Hatami, M. R. Tousi, P. Bayat, P. Bayat, Power management strategy for hybrid vehicle using a three-port bidirectional DC-DC converter, *23rd Iranian Conference on Electrical Engineering (ICEE)*, (2015), pp.1498-1503.
- [40] Billinton R, Jonnavithula S. A Test System For Teaching Overall Power System Reliability Assessment. *IEEE Transactions on Power Systems*, Vol.11, No.4, (1996), pp.1670-1676.
- [41] R. Karki, R. Billinton, Reliability/cost implications of PV and wind energy utilization in small isolated power systems, *IEEE Transaction on Energy Conversion* Vol.16, (2001), pp.368-373.
- [42] R. N. Allan, R. Billinton, I. Sjarief, L. Goel, So KS. A reliability test system for educational purposes-basic distribution system data and results. *IEEE Transactions on Power Systems*, Vol.6, No.2, (1991), pp.813-820.
- [43] W. Li, Reliability assessment of electrical power systems using Monte Carlo methods, *Springer Science & Business Media*, (1994).
- [44] D. Jager, A. Andreas, NREL national wind technology center (NWTC): M2 Tower; Boulder, Colorado (Data). NREL Report No. DA-5500-56489. https://midcdmz.nrel.gov/nwtc_m2/
- [45] M. Jalali, K. Zar, H. Seyedi, Strategic decision-making of distribution network operator with multi-microgrids considering demand response program, *Energy*, Vol.141, (2017), pp.1059-1071.

[46] Zhu J, Gu W, Jiang P, Song S, Liu H, Liang H, Wu M. Dynamic Island Partition for Distribution System with Renewable Energy to Decrease Customer Interruption Cost. *J Electr Eng Technol*, Vol.12, No.6, (2017), pp.2146-2156.

[47] R. Billinton, R. N. Allan, *Reliability evaluation of power systems*, Plenum press New York, Vol.2, (1984).