



# A Fuzzy Approach to Sequential Failure Analysis Using Petri nets

A. Doostparast Torshizi & S.R. Hejazi\*

Abolfazl Doostparast Torshizi, Master student of Industrial Engineering, Isfahan University of Technology, Isfahan, Iran  
Seyed Reza Hejazi, Associate Professor, Department of Industrial Engineering, Isfahan University of Technology, Isfahan, Iran

## KEYWORDS

Fuzzy logic, Similarity  
Measures, Failure Analysis,  
Petri nets

## ABSTRACT

*In highly competitive industrial market, the concept of failure analysis is an unavoidable fact in complex industrial systems. Reliability of such systems not only depends on the reliability of each element of these systems, but also depends on occurrence of sequence of failures. In this paper, a novel approach to sequential failure analysis is proposed which is based upon fuzzy logic and the concept of Petri nets which is utilized to track all the risky behaviors of the system and to determine the potential failure sequences and then prioritizing them in order to perform corrective actions. The process of prioritizing failure sequences in this paper is done by a novel similarity measure between generalized fuzzy numbers. The proposed methodology is demonstrated with an example of two automated machine tools and two input/output buffer stocks.*

© 2010 IUST Publication, IJIEPR, Vol. 21, No. 2, All Rights Reserved.

## 1. Introduction

Nowadays, highly competitive market has forced industrial companies to evaluate their complex systems in order to prevent these complex systems to be faulty. Due to this fact, reliability analysis of such complex systems necessitates the use of combinatorial approaches in order to evaluate these systems and perform corrective actions to avoid such failures. In highly complicated industrial systems, failure states of the systems not only occur upon failure of each subsystem, but also take place according to sequences of failures. For instance, in nuclear reactors, there is a sophisticated cooling system which implements a principal and a standby cooling device. Any time that the main device fails, the standby one starts to operate and prevents the reactor from overheating. Now suppose that the principal device is

out of order and the reserve one is operating. In this situation, failure of the standby device will lead in overheating or even explosion of the reactor.

The sequence of the two failures (first the failure of the standby device then the failure of the principal cooling device) is an example of sequential failures. Sequential failure analysis involves modeling the sequential failure logic, identifying critical sequential failures, and computing the probability of the sequential failures [12].

Current failure analysis techniques are not capable of evaluating the sophisticated industrial systems and are based on unrealistic assumptions which are not intuitively comprehensive so that they are not able to manage risky behaviors of the system and predict potential sequential failures of systems which lead to catastrophic incidents like what happened in former soviet nuclear power plant, Chernobyl, which contaminated tens of thousands of hectares of the region and resulted in thousands of casualties.

A recent approach in this field is proposed by Adamyan and He [12], which incorporates the concept

Corresponding author. S.R. Hejazi

Email: [rehejazi@cc.iut.ac.ir](mailto:rehejazi@cc.iut.ac.ir)

Paper first received April. 12. 2010 ,and in revised form August. 28. 2010.

of counters of Petri Nets in sequential failure analysis. This approach is to some extent a realistic thinking but it does not seem to be versatile, since it uses deterministic probabilities in describing failure probabilities of each subsystem. On the other hand, however, fuzzy logic is more versatile and less vulnerable because with using linguistic variables, evaluation of sequential failures is closer to the facts due to human intuition.

In this paper, we present an alternative methodology for assessing failures in a complex system based on the concept of fuzzy logic. In some previous researches, in order to overcome the limitations of traditional methods, concept of counters in Petri net simulation to develop new methods for sequential analysis were used.

In order to make this approach, we present an integrated approach which incorporates fuzzy logic in the concept of Petri nets to develop a new sequential analysis technique. The developed method is demonstrated with an example of an automated machining and assembly system.

The remainder of this paper is organized as follows. In section 2 of the paper an overview on Petri nets, fuzzy logic and its applications in safety analysis, and finally a similarity measure between generalized fuzzy numbers which is utilized in the next sections is presented. In section 3 the developed methodology of failure analysis is demonstrated. Section 4 of the paper presents an illustrative example including two CNC machine tools and two input/ output buffer stocks.

## 2. An Overview

### 2.1. Petri Nets

Petri nets are a graphical and mathematical modeling tool applicable to many systems. They offer formal graphical description possibilities for modeling of systems consisting of concurrent processes. Petri nets have been used extensively as a tool for modeling, analysis and synthesis for discrete event systems. As a graphical tool, Petri nets can be used as a visual communication aid similar to flow charts, block diagrams, and networks. In addition, tokens are used in these nets to simulate the dynamic and concurrent activities of systems.

The origin of Petri nets has its origin in Carl Adam Petri's PhD dissertation [1]. For more information about the origin and the evolution of Petri nets, reader is referred to [1], [2].

A Petri net (PN) is a 5-tuple,  $PN = (P, T, F, W, M_0)$  where:

- $P = \{p_1, p_2, \dots, p_m\}$  is a finite set of places.
- $T = \{t_1, t_2, \dots, t_n\}$  is a finite set of transitions.
- $F \subseteq (P \times T) \cup (T \times P)$  is a set of arcs (flow relations).
- $W: F \rightarrow \{1, 2, 3, \dots\}$  is a weight function.
- $M_0: P \rightarrow \{0, 1, 2, \dots\}$  is the initial marking.
- $P \cap T = \emptyset$  and  $P \cup T = \Phi$

The dynamic behavior of a system is modeled by changing the state or marking in Petri nets according to the following (firing) rules:

- 1- A transition  $t$  is said to be enabled if each input place  $p$  of  $t$  is marked with at least  $w(p, t)$  tokens, where  $w(p, t)$  is the weight of the arc from  $p$  to  $t$ .
- 2- An enabled transition may or may not fire depending on whether or not the event actually takes place (firing conditions are ok).
- 3- Firing of an enabled transition  $t$  removes  $w(p, t)$  tokens from each input place  $p$  to  $t$  and adds  $w(t, p)$  tokens to each output place  $p$  of  $t$ , where  $w(p, t)$  and  $w(t, p)$  are the weights of the arcs from  $p$  to  $t$  or  $t$  to  $p$  respectively. In graphical representation of a Petri net, places are represented by circles and transitions are shown by hollow bars.

The relationship between places and transitions is represented by directed arcs. For example the Petri net of Fig. 1. depicts the firing of a transition. In un-timed Petri net one can prohibit controlled transition from firing but cannot force the firing of a transition at a particular time.

In a timed Petri net controlled transitions are forced to fire, by considering the time dependent firing functions. In timed Petri nets, each transition has its specific time which determines the transition's holding time. When a transition is fired during its holding time, the network's marking is not changed and as soon as its holding time elapsed the marking of network will be changed based on the mentioned firing rules.

Application of Petri nets in failure analysis is an active field of research which is emerging day by day. The application of PNs is similar to application of fault and event tree analysis which are two strong graphical tools for pre-post event reliability and risk analysis. As this is a rather new field, one cannot find a vast variety of approaches but some researches such as safety analysis and reliability growth [3], [4]; reliability evaluation [5], [6], [7]; reliability of manufacturing systems [8], [9], [10]. Assessment of system reliability and safety of complex industrial systems is an enormous and time consuming task that can become incredibly easier by implementing PNs. In [11] an approach is proposed for identification of sequences of failures which is very efficient for system reliability prediction, however, it assumes that the times to failures are exponentially distributed.

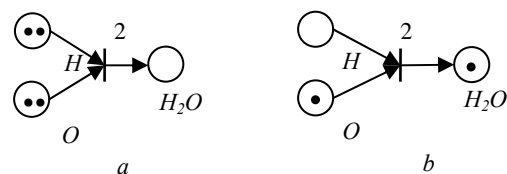
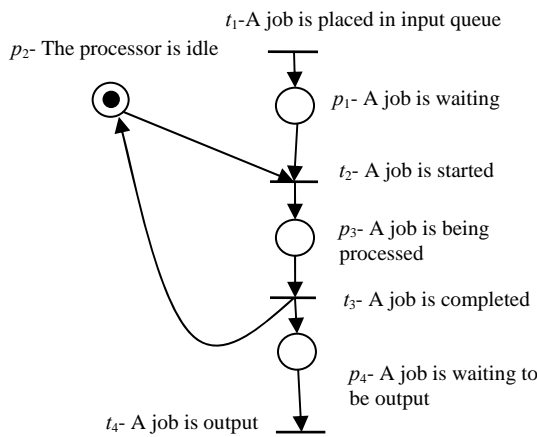

Fig. 1. Transition (firing): (a) Marking before firing (b): Marking after firing



**Fig. 2. Sensor model implementation in semi-active control system design**

Some researchers believe that PNs can be an appropriate alternative for FTA [4], [5], since it not only graphically symbolizes the cause and effect relationship among the events, but also represent dynamic behavior of the system.

Fault trees which are basic graphical risk analysis tools can be transformed to Petri nets that for more explanation, readers can refer to [4].

**2.2. Fuzzy Logic and its Applications in Safety Analysis**

Due to easy implementation and adaptability, Fuzzy logic has become a major part in assessment of reliability of systems. Many different approaches in this field have been introduced so far. In [12] a fuzzy risk analysis method based on a new similarity measure between fuzzy numbers is proposed. Failure mode and effect analysis (FMEA) using fuzzy weighted geometry mean is proposed by Wang *et al.* [13]. Most of approaches in application of fuzzy logic are concentrated on using fuzzy arithmetic relationships such as ranking techniques of fuzzy numbers and similarity measures between fuzzy numbers; for more detailed explanation reader is referred to [14-17].

Uncertain and inadequate information in man-made systems may cause severe catastrophes. One of such systems are aircrafts in which right working state is a key factor to ensure airplane normal and secure; hence, in [21] a fault diagnosis method based on adaptive fuzzy Petri nets is proposed. In this research firstly, a fuzzy Petri net by using fuzzy production rules is constructed and then weights of fuzzy Petri net are trained by neural network. Finally, the fault origin can be diagnosed. In [22] fuzzy Lambda-Tau methodology is been incorporated in reliability modeling of repairable systems. In this research some reliability parameters such as mean time to failure, availability, mean time to repair and unavailability, and reliability of systems are obtained by Petri nets where different

connections of the nets are converted by Lambda-tau methodology to handle vagueness of reliability measuring in repairable systems.

Fault detection and diagnosis is an active field of research. In order to improve accuracy and efficiency of fault diagnosis many approaches have been presented so far. On the other hand, fuzzy logic and Petri nets have been utilized extensively in this field. For more details in this field reader is referred to [23-24].

Our main approach in this paper is concentrated on sequential failure analysis. In [23], sequential failure analysis basics are defined and described and on their basis, a method for safety assessment of systems is proposed. One of the main recent researches in this field is [24]. In this research algebraic equations called counters are obtained for different kinds of connections of stochastic Petri nets. The concept of counters aims in finding the number of times a failure, demonstrated by a transition, has occurred. Based on this concept, the probability of happening a sequence of failures is calculated. As it can be seen, a restricted number of researches have concentrated on the issue of sequential failure analysis. On the other hand, none of them have considered the vagueness instinctively existed in safety assessment of systems. Also, our approach eases evaluation of risk in manufacturing systems since, more complex systems can be evaluated by similarity measures utilized in this paper and there would be no need to perform extra activities to prioritize risky behaviors of the systems.

**2.2.1. Preliminaries**

In this section we briefly describe the basic concepts of generalized fuzzy numbers. The concept of generalized was proposed first in [18].

Let  $\tilde{A}$  be a generalized trapezoidal fuzzy number,  $\tilde{A} = (a_1, a_2, a_3, a_4, W_{\tilde{A}})$ , as shown in Fig. 3., where  $a_1, a_2, a_3, a_4$  are real values,  $W_{\tilde{A}}$  denotes the height of the generalized fuzzy number  $\tilde{A}$ , and  $W_{\tilde{A}} \in [0,1]$ . If

$1 \leq a_1 \leq a_2 \leq a_3 \leq a_4 \leq 1$ , then  $\tilde{A}$ , is called a standardized generalized fuzzy number. If  $W_{\tilde{A}} = 1$ , then  $\tilde{A}$  becomes a traditional fuzzy number and can be represented as

$\tilde{A} = (a_1, a_2, a_3, a_4)$ . If  $a_2 = a_3$  then  $\tilde{A}$  is a triangular fuzzy number. If  $a_1 = a_2 = a_3 = a_4$ , then  $\tilde{A}$  is a crisp value. Now

we briefly describe some arithmetic operations between generalized fuzzy numbers. Assume that  $\tilde{A}$  and  $\tilde{B}$  are two trapezoidal generalized fuzzy numbers where

$\tilde{A} = (a_1, a_2, a_3, a_4, W_{\tilde{A}}), \tilde{B} = (b_1, b_2, b_3, b_4, W_{\tilde{B}}), a_1, a_2, a_3, a_4, b_1, b_2, b_3$  and  $b_4$  are real values, and  $0 \leq W_{\tilde{A}}, W_{\tilde{B}} \leq 1$ . Some arithmetic operations between the generalized fuzzy numbers  $\tilde{A}$  and  $\tilde{B}$  are shown as follows:

Generalized fuzzy numbers addition  $\oplus$ :

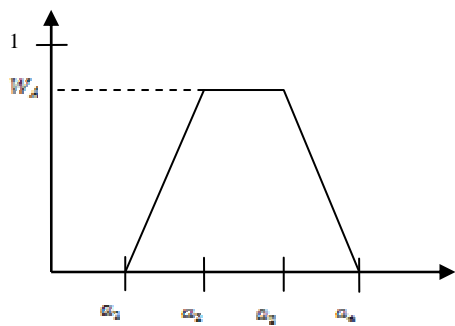

Fig. 3. A generalized fuzzy number  $\tilde{A}$

$$A \oplus \tilde{B} = (a_1, a_2, a_3, a_4, W_{\tilde{A}}) \oplus (b_1, b_2, b_3, b_4, W_{\tilde{B}})$$

$$= (a_1 + b_1, a_2 + b_2, a_3 + b_3, a_4 + b_4; \min(W_{\tilde{A}}, W_{\tilde{B}})) \quad (1)$$

Generalized fuzzy numbers division  $\oplus$ :

If  $a_1, a_2, a_3, a_4, b_1, b_2, b_3$  and  $b_4$  are all nonzero positive real numbers, then we have:

$$\frac{A}{\tilde{B}} = \frac{(a_1, a_2, a_3, a_4, W_{\tilde{A}})}{(b_1, b_2, b_3, b_4, W_{\tilde{B}})}$$

$$= \left( \frac{a_1}{b_4}, \frac{a_2}{b_3}, \frac{a_3}{b_2}, \frac{a_4}{b_1}; \min(W_{\tilde{A}}, W_{\tilde{B}}) \right) \quad (2)$$

Generalized fuzzy numbers multiplication :

$$A \otimes \tilde{B} = (a, b, c, d; \min(W_{\tilde{A}}, W_{\tilde{B}}))$$

Where  $a = \min(a_1 \times b_1, a_4 \times b_1, a_1 \times b_4, a_4 \times b_4)$ ,  
 $b = \min(a_2 \times b_2, a_2 \times b_3, a_2 \times b_2, a_3 \times b_2)$ ,  
 $c = \max(a_2 \times b_2, a_2 \times b_3, a_2 \times b_2, a_3 \times b_2)$ ,  
 $d = \max(a_1 \times b_1, a_4 \times b_1, a_1 \times b_4, a_4 \times b_4)$

If  $a_1, a_2, a_3, a_4, b_1, b_2, b_3$  and  $b_4$  are positive real numbers, then we have:

$$A \otimes \tilde{B} = (a_1 \times b_1, a_2 \times b_2, a_3 \times b_3, a_4; \min(W_{\tilde{A}}, W_{\tilde{B}})) \quad (3)$$

### 2.2.1. Similarity Measures Between Fuzzy Numbers

Similarity measures between fuzzy numbers are a broad field of interest for many researchers. In order to make readers more familiar with these techniques, we introduce one of the latest approaches proposed, and we will then adopt it in our methodology in section three of the paper. The method being adopted in our methodology is based on the model by Wei & Chen [12] which is developed by Doostparast *et al.* In this method the geometric distance, the perimeter of the two fuzzy numbers and the area of the two fuzzy numbers are considered.

Let  $\tilde{A}$  and  $\tilde{B}$  be two generalized trapezoidal fuzzy numbers, where  $\tilde{A} = (a_1, a_2, a_3, a_4; W_{\tilde{A}})$  and  $\tilde{B} = (b_1, b_2, b_3, b_4; W_{\tilde{B}})$ ,  $1 \leq a_1 \leq a_2 \leq a_3 \leq a_4 \leq 1$  and  $0 \leq b_1 \leq b_2 \leq b_3 \leq b_4 \leq 1$ .

Here is the measure of similarity that will be used in other sections of the paper.

$$S(\tilde{A}, \tilde{B}) = \left( 1 - \frac{\sum_{i=1}^4 |a_i - b_i|}{4} \right) \times \frac{\min(P(\tilde{A}), P(\tilde{B}))}{\max(P(\tilde{A}), P(\tilde{B}))}$$

$$\times \frac{\min(A(\tilde{A}), A(\tilde{B})) + \min(W_{\tilde{A}}, W_{\tilde{B}})}{\max(A(\tilde{A}), A(\tilde{B})) + \max(W_{\tilde{A}}, W_{\tilde{B}})} \quad (4)$$

$P(\tilde{A})$  and  $P(\tilde{B})$  are the perimeters of the two generalized trapezoidal fuzzy numbers which are calculated as follows:

$$P(\tilde{A}) = \sqrt{(a_1 - a_2)^2 + W_{\tilde{A}}^2} + \sqrt{(a_3 - a_4)^2 + W_{\tilde{A}}^2} + (a_3 - a_2) + (a_4 - a_1) \quad (5)$$

$$P(\tilde{B}) = \sqrt{(b_1 - b_2)^2 + W_{\tilde{B}}^2} + \sqrt{(b_3 - b_4)^2 + W_{\tilde{B}}^2} + (b_3 - b_2) + (b_4 - b_1) \quad (6)$$

On the other hand we have  $A(\tilde{A})$  and  $A(\tilde{B})$  which are the areas of the two fuzzy numbers  $\tilde{A}$  and  $\tilde{B}$  that are calculated as follows:

$$A(\tilde{A}) = \frac{1}{2} W_{\tilde{A}} (a_3 - a_2 + a_4 - a_1) \quad (7)$$

$$A(\tilde{B}) = \frac{1}{2} W_{\tilde{B}} (b_3 - b_2 + b_4 - b_1) \quad (8)$$

### 2.3. General Framework of Sequential Failure Analysis

In the literature of reliability and risk analysis, the methodology for sequential failure analysis is like what is depicted in Fig. 4. This methodology incorporates FTA and failure mode and effect analysis (FMEA) and dynamic Petri net modeling for identifying all possible failures and their sequences of occurrence. In this framework, the concept of counters in Petri nets is used in order to compute the sequential failure probabilities. As it is shown in Fig. 4., the framework of sequential failure analysis consist of five steps. The aim of this paper is to develop incorporation of fuzzy logic in the fifth step, while first four steps are discussed in other researches [12]-[20]. Sequential failure analysis steps starts with using FMEA or FTA techniques in order of prediction of all failures which are potent to occur. Although FMEA is a general term, it is divided to different branches such as Quality FMEA (QFMEA), Design FMEA (DFMEA) and Process FMEA (PFMEA). The second step, Petri net modeling, includes modeling the system in a dynamically manner

so that all tasks and activities taking place in the system can be seen. The first two steps are dependent to each other any change in any of them will change the status of the other one. Integration of potential failures resulting from the first and the second step into the Petri net builds the third step that is a critical step in failure analysis since it enables the auditor to view all potential risky activities in the system on the Petri net in an online manner. Based on the Petri net model, a reachability tree can be constructed by firing all possible transitions enabled an all reachable markings starting from the initial marking [2]. This procedure continues until all states of the system are represented. As a result, the entire system representation includes both normal operation flow of the system and all possible failures. Based on the marking representation, the sequences of the failures can be obtained by following the reachability tree starting from the initial marking toward the marking that represents the system failure state. By following the paths that bring to system failure markings, the sequences of the failures are identified.

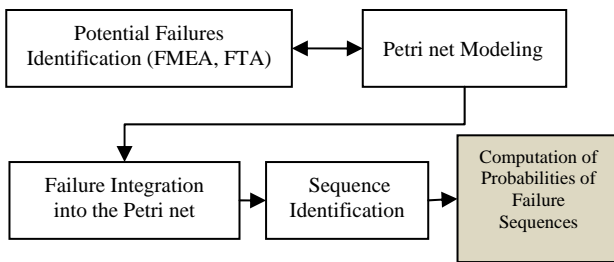

**Fig. 4. Framework of sequential failure analysis**

In the literature, other approaches for failure sequence identification are proposed. In [20], the authors dealt with estimation of firing and enabling sequences for timed transition Petri nets with unknown time delays. This estimation method provides both exact and approximated solutions. The method is also suitable for identification applications in the case of deterministic or stochastic timed Petri nets with unknown minimal time delays.

Once the sequences of the failures are identified, the probability of their occurrence can be computed in the last step. Our main intention in this paper is to focus on this step. The proposed methodology does not compute the probability of firing of transitions of the Petri net since in real cases, one can claim that determination of probability of failure in each activity by only using schematic form of Petri nets is impossible. Hence, we adopt fuzzy logic to make sequential failure analysis more realistic and easy to implement.

**3. Developed Methodology for Failure Analysis**

In this section, we propose an algorithm for ranking risky behaviors of the system and prioritize

them in order to perform corrective actions. To evaluate the risk of each failure and its sequential failure risk, Petri net model of the system is drawn and all the predecessor activities which lead to a specific activity are shown and considered, then the tree risk factors of Detection, Severity, and Occurrence of each of these activities are converted to a list of linguistic variables and by using arithmetic relationships between fuzzy numbers, the risk priority number of the risky chain is calculated. When considering numbers of failure chains, in order to rank them to perform corrective actions in a timely manner, we use the similarity measure explained in section two of the paper to find out which failure chain is more potent of happening. Here is the proposed algorithm for evaluating and prioritizing risky failure chains of the system:

- Step 1:** Draw the Petri net model of the system where all the probable behaviors of the system are considered.
- Step 2:** Determine all activities (transitions of the PN) which are considered as the end activity of a chain.
- Step 3:** Determine three risk factors of Detection, Severity, and Occurrence of each of the activities in the considered chain due to linguistic variables of Tab. 1.
- Step 4:** In order to attain the failure risk of the considered chain, multiply all the risk priority numbers of the transitions of the chain in order to get the risk priority number of the chain.
- Step 5:** Using similarity measure of section two of the paper and the ingredients of Tab. 1., rank the risk of failure chains in order to perform corrective actions.

**Tab. 1. A 9-member linguistic term set (Zhang, 1986)**

Linguistic Terms	Generalized fuzzy numbers
Absolutely-low	(0, 0, 0, 0; 1.0)
Very-low	(0, 0, 0.02, 0.07; 1.0)
Low	(0.04, 0.1, 0.18, 0.23; 1.0)
Fairly-low	(0.17, 0.22, 0.36, 0.42; 1.0)
Medium	(0.32, 0.41, 0.58, 0.65; 1.0)
Fairly-high	(0.58, 0.63, 0.80, 0.86; 1.0)
High	(0.72, 0.78, 0.92, 0.97; 1.0)
Very-high	(0.93, 0.98, 1.0, 1.0; 1.0)
Absolutely-high	(1.0, 1.0, 1.0, 1.0; 1.0)

**4. An Illustrative Example**

In order to make the proposed methodology more explicit, we apply this safety analysis technique in a schematic automated workcell which consists of a robotic arm and two CNC machine tools. The graphical representation of this workcell is been depicted in Fig. 5. Due to the proposed algorithm in section three of the paper, in order to determine the failure sequences potent to occur and then prioritizing them, the Petri net



model of the automated workcell is drawn at first in Fig. 7. and the interpretation of each place and transition of this Petri net is in Tab. 2. and 3 respectively.

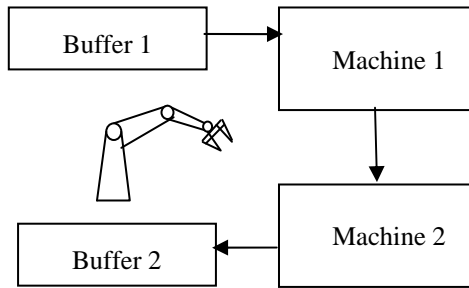

Fig. 5. An automated workcell

Here we select two different activities which are potent to happen. Although there might exist more probable failures to happen, in order to show the capability and ease of implementation of the proposed method, we just compare two of these possible failures. The considered failures are as follows:

- 1- Robot failure.
- 2- Buffer2 failure.

Here we implement the proposed algorithm and then prioritize these three potential failures.

**Algorithm:**

**Step1:** The Petri net model of the system is drawn in Fig. 6.

**Step2:** In this step, the all the activities that may lead to the considered probable failures are identified. Here we have:

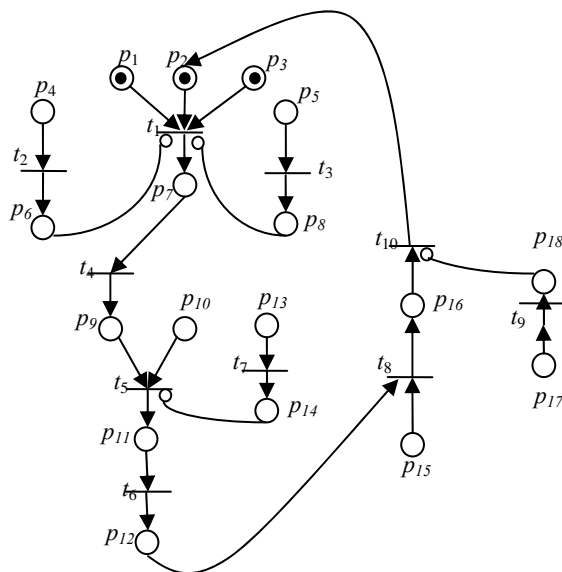

Fig. 6. Petri net model of fig. 6. to determine failure chains

Tab. 2. Interpretation of places of fig. 7.

Place	Interpretation
$p_1$	A part is ready from buffer1
$p_2$	Robot ready
$p_3$	Machine1 ready for operation
$p_4$	Machine1 ready to fail
$p_5$	Robot ready to fail
$p_6$	Machine1 failure
$p_7$	Machne1 operation ended
$p_8$	Robot failure
$p_9$	Machine1 is unloaded
$p_{10}$	Machine2 ready
$p_{11}$	Machine2 is loaded
$p_{12}$	Operation on Machine2 ended
$p_{13}$	Machine2 ready to fail
$p_{14}$	Machine2 failure
$p_{15}$	Robot ready
$p_{16}$	Final part ready
$p_{17}$	Buffer2 ready to fail
$p_{18}$	Buffer2 failure

Tab. 3. Interpretation of transitions of fig. 7.

Place	Interpretation
$t_1$	Machine1 is operating
$t_2$	Machine1 failure occurred
$t_3$	Robot failure occurred
$t_4$	Unloading machine1
$t_5$	Robot is handling the part
$t_6$	Machine2 operating
$t_7$	Machine2 failure occurred
$t_8$	Unloading machine2
$t_9$	Buffer2 failure occurred
$t_{10}$	Loading buffer2

1- Robot failure: failure of the robot not only prevents the robot from performing its task, but also prevents the machine1 from operation. Here we can track this process on the Petri net:  $p_5 \rightarrow p_8$  and  $p_4 \rightarrow p_6$ .

2- Buffer2 failure: failure of the second buffer leads to first: its failure and then stopping robot from performing its job, respectively, so that it forms a failure chain which can be tracked on the Petri net.

**Step3:** In this step using technique of FMEA, we determine the aggregation risk priority numbers of the considered chains and by multiplying the risk priority numbers of the elements of each chain.

Here we perform the procedure for the two failure chains and then by using arithmetic relation (multiplication) of the fuzzy numbers, the risk priority number of each chain is calculated. The risk factors considered for each failure is as follows that is based on the intuition of the writer:

1- Robot failure:

Place8:

Occurrence factor: Very-low

Severity factor: High

Detection factor: Very -low  
 Fuzzy risk priority number for place8:  
 FRPN: (Very-low)⊗(High)⊗(Very-low) = (0, 0, 0.02, 0.07; 1.0) ⊗ (0.72, 0.78, 0.92, 0.97; 1.0) ⊗ (0, 0, 0.02, 0.07; 1.0) = (0, 0, 0.00037, 0.0048; 1.0)

Place6:  
 Occurrence factor: Fairly-low  
 Severity factor: High  
 Detection factor: Fairly-low

Fuzzy risk priority number for place6:  
 FRPN: (Fairly-low)⊗(High)⊗(Fairly-low) = (0.17, 0.22, 0.36, 0.42; 1.0) ⊗ (0.72, 0.78, 0.92, 0.97; 1.0) ⊗ (0.17, 0.22, 0.36, 0.42; 1.0) = (0.021, 0.378, 0.119, 0.171; 1.0)

2-Buffer2:  
 Place18:  
 Occurrence factor: Low  
 Severity factor: High  
 Detection factor: Medium

Fuzzy risk priority number for place18:  
 FRPN: (Low)⊗(High)⊗(Medium) = (0.04, 0.1, 0.18, 0.23; 1.0) ⊗ (0.72, 0.78, 0.92, 0.97; 1.0) ⊗ (0.32, 0.41, 0.58, 0.65; 1.0) = (0.0092, 0.032, 0.096, 0.145; 1.0)

Place6:  
 Occurrence factor: Fairly-low  
 Severity factor: High  
 Detection factor: Fairly-low

Fuzzy risk priority number for place6:  
 FRPN: (Fairly-low)⊗(High)⊗(Fairly-low) = (0.17, 0.22, 0.36, 0.42; 1.0) ⊗ (0.72, 0.78, 0.92, 0.97; 1.0) ⊗ (0.17, 0.22, 0.36, 0.42; 1.0) = (0.021, 0.0378, 0.119, 0.171; 1.0)

Aggregate FRPN of the chain: = (0, 0, 0.00037, 0.0048; 1.0) ⊗ (0.021, 0.378, 0.119, 0.171; 1.0) = (0, 0, 0.000044, 0.00082; 1.0)

Step4: Using fuzzy multiplication of generalized fuzzy numbers, the aggregate fuzzy risk priority number of each chain is calculated:

Aggregate FRPN of the chain 1 = (0, 0, 0.00037, 0.0048; 1.0) ⊗ (0.021, 0.378, 0.119, 0.171; 1.0) = (0, 0, 0.000044, 0.00082; 1.0)

Aggregate FRPN of the chain 2 = (0.0092, 0.032, 0.096, 0.145; 1.0) ⊗ (0.021, 0.0378, 0.119, 0.171; 1.0) = (0.00019, 0.0012, 0.0114, 0.0248; 1.0)

Step5: Here in the last step, using the presented similarity measure between generalized fuzzy numbers in section 2 of the paper we determine which of these chains has more priority on the other one to perform corrective action on.

**Chain 1:**

Linguistic Terms	Similarity measure
Absolutely-low	0.9989
Very-low	0.8955
Low	0.6694
Fairly-low	0.4954
Medium	0.3259
Fairly-high	0.1883
High	0.1069
Very-high	0.0208
Absolutely-high	0.00216

**Chain 2:**

Linguistic Terms	Similarity measure
Absolutely-low	0.9897
Very-low	0.9033
Low	0.6765
Fairly-low	0.5018
Medium	0.3318
Fairly-high	0.1945
High	0.1133
Very-high	0.0292
Absolutely-high	0.00939

Apparently, in both chains the aggregate failure risk chain equals with Absolutely-high which shows the equality of these two failure chains in priority of corrective action.

As it can be seen, the proposed method can handle sequential failure analysis and prioritizing of potential risks, simultaneously. On the other hand, the method presented in [24] is not able to consider different risky sequences and to prioritize them. On the other hand, more complex systems can be evaluated by the proposed methodology, while large computations does not let methods of [23] and [24] to do such a job.

**5. Conclusion**

Identification of sequential failures plays an important role in keeping complex industrial systems safe. Here in this paper, a novel methodology based on Petri nets and similarity measures between generalized fuzzy numbers is proposed. This method enables the auditor of the systems to track all faulty behaviors of the system dynamically and rank them using fuzzy logic and the arithmetic relations between fuzzy numbers.

**References**

[1] Petri, C.A., "Kommunikation Mmit Automaten," Bonn: Institut fur Instrumentelle Mathematik. Schriften des IIM Nr. 3, 1962.  
 [2] Murata, T., "Petri Nets: Properties, Analysis and Applications," Proc. IEEE, Vol. 77, No. 4, 1989, pp. 541-580.

- [3] Levenson, N., Stolzy, J., "Safety Analysis Using Petri Nets," *IEEE Trans. Software Eng.*, Vol. SE-13, 1987, pp. 386-397.
- [4] Yang, S., Liu, T., "Failure Analysis for an Airbag Inflator by Petri Nets," *Qual. Reliab. Eng. Int.*, Vol. 13, No. 3, 1997, pp. 139-151.
- [5] Liu, T.S., Chiou, B.S., "Application of Petri Nets to Failure Analysis," *Reliab. Eng. Syst. Safety*, Vol. 57, 1997, pp. 129-142.
- [6] Hura, G., Atwood, J., "The use of Petri Nets to Analyze Coherent Fault Trees," *IEEE Trans. Rel.*, Vol. 37, 1988, pp. 469-474.
- [7] Kumar, V., Aggrawal, K., "Petri Net Modeling and Reliability Evaluation of Distributed Processing Systems," *Reliab. Eng. Syst. Safety*, Vol. 41, No. 2, 1993, pp. 167-176.
- [8] Jiang, C., Diao, B., Wu, F., "Study on Reliability of Manufacturing Systems Based on Petri Net," *High Tech. Lett.*, Vol. 1, No. 2, 1995, pp. 25-30.
- [9] Xiong, H., He, Y., "GSPN Based Reliability Modeling and Analysis of CIMS," *Mech. Sci. Technol.*, Vol. 16, 1997, pp. 1103-1106.
- [10] Kuo, C.H., Huang, H.P., "Failure Modeling and Process Monitoring for Flexible Manufacturing Systems Using Colored Timed Petri Nets," *IEEE Trans. Robot. Automat.*, Vol. 16, 2000, pp. 301-312.
- [11] Adamyan, A., He, D., "Analysis of Sequential Failure for Assessment of Reliability and Safety of Manufacturing Systems," *Reliab. Eng. Syst. Saf.*, Vol. 76, 2002, pp. 227-236.
- [12] Wei, S.H., Chen, S.M., "Anew Approach for Fuzzy Risk Analysis Based on Similarity Measures of Generalized Fuzzy Numbers," *Expert Systems with Applications*, Vol. 36, 2009, pp. 589-598.
- [13] Wang, Y.M., Chin, K.S., Poon, G.K.K., Yanj, J.B., "Risk Evaluation in Failure Mode and Effect Analysis Using Fuzzy Weighted Geometric Mean," *Expert Systems with Applications*, Vol. 36, 2009, pp. 1195-1207.
- [14] Chen, S.M., Wang, C.H., "Fuzzy Risk Analysis Based on Ranking Fuzzy Numbers Using  $\alpha$ -Cuts, belief features and signal/noise ratios," *Expert Systems with Applications*, ARTICLE IN PRESS, 2008.
- [15] Chen, J.H., Chen, S.M., "A New Method for Ranking Generalized Fuzzy Numbers for Handling Fuzzy risk Analysis Problems," *Proc. 9<sup>th</sup> Conf. Info. Sci.*, 2006, pp. 1196-1199.
- [16] Chen, S.M., "New Methods for Subjective Mental Workload Assessment and Fuzzy Risk Analysis," *Cybernetics and Systems*, Vol. 27, No. 5, 1996, pp.449-472.
- [17] Hsieh, C.H., Chen, S.H., "Similarity of Generalized Fuzzy Numbers with Graded Mean Integration Representation," *Proc. 8<sup>th</sup> Int. Fuzzy. Syst. Assoc. World. Cong.*, Vol. 2, 1999, pp. 551-555.
- [18] Chen, S.H., "Operations on Fuzzy Numbers with Function Principal," *Tamkang Journal of Management Sciences*, Vol. 6, no. 1, 1985, pp. 13-25.
- [19] He, D., & Adamyan, A., "An Impact Analysis Methodology for Design of Product and Process for Reliability and Quality," *Proc. 6<sup>th</sup> Design Manufacturing Conf.*, 2001.
- [20] Lefebvre, D., Moudni, A., "Firing and Enabling Sequential Estimation for Timed Petri Nets," *IEEE Trans. Syst. Man. Cybern.*, Vol. 31, 2001, pp. 153-162.
- [21] Lan, J., Ma, M., "Fault Diagnosis Method of Power System Based on the Adaptive Fuzzy Petri Net", *Proc. IEEE circuits and systems international conference on testing and diagnosis*, 2009.
- [22] Knezevic, J., Odoom, E.R., "Reliability Modeling of Repairable Systems Using Petri Nets and Fuzzy Lambda-Tau methodology", *Reliability Engineering and system safety*, Vol. 73, 2001, pp. 1-17.
- [23] Liu, L., Wang, W., "Research on Complex Equipment Fault Diagnosis Based on Weighted Fuzzy Logic Petri Nets", *Proc. International Conference on Computer and Electrical Engineering*, 2009.
- [24] Chen, L., Tan, H., Li, S., "Implementation of Web-Based Fault Diagnosis Using Improved Fuzzy Petri Nets" *Proc. 6<sup>th</sup> International Conference on Fuzzy Systems and Knowledge Discovery*, 2009.
- [25] Adamyan, A., He, D., "Analysis of Sequential Failure for Assessment of Reliability and Safety of Manufacturing Systems", *Reliability Engineering and System Safety*, Vol. 76, 2002, pp. 227-236.
- [26] Adamyan, A., He, D., "Sequential Failure Analysis Using Counters of Petri Nets Models", *IEEE Trans. On Systems, Man, and Cybernetics*, Vol. 33, No. 1, 2003, pp. 1-11.