



# A Preliminary Investigation into Geometry, Represented by Parameters, and its Effect on Function and Manufacturing Attributes

A. Azizi,\* V. Boppana & A.C. Clement

A. Azizi, Harris, The University of the West Indies, St Augustine  
V. Boppana, Chowdary, The University of the West Indies, St Augustine,  
A.C. Clement, Imbert, The University of the West Indies, St Augustine

## KEYWORDS

CAD, CAE,  
Product Design and Development,  
Functions, Parameters,  
Design Table

## ABSTRACT

*This paper demonstrates a preliminary investigation of geometry, function and its relation to DFX principles, namely DFM (Design for Manufacturing). This is the starting point for research on the development of an expert system that assesses design goals along DFX principles in a feature-based CAD environment. There is a need for a deeper level of understanding of the relationship between geometry and its effects on function, in order to correct and improve the product concept before large amounts of resources are invested in the product's development.*

*This paper is a preliminary investigation into geometry and function involving DFM as part of an early stage of research into geometric effects on function and DFX through the use of CAD/CAE/CAM. In this paper, a concept is chosen to develop a parametric solid model that will be used to investigate a set of defined function attributes using model variants, which are evaluated in terms of the defined function attributes and DFM. The investigation found that for the functions defined, geometric parameters had less of an effect than expected. This is mainly due to the fact that the defined function attributes under investigation were associated with material properties. This paper demonstrates a preliminary investigation at the early stage of research to develop a more detailed relationship structure between geometry and functional attributes and their relationship with DFX. The end goal is to develop an integrated methodology involving geometry, function and DFX principles through the use of CAD/CAE/CAM.*

© 2011 IUST Publication, IJIEPR, Vol. 22, No. 4, All Rights Reserved.

## 1. Introduction

The geometry of a concept can influence the functions of the concept and can greatly affect every single aspect of the product development cycle. As a result, geometry determines the costs, quality,

environmental impact and customer satisfaction of a product. There is not much evidence of research involving geometry and function as it relates to DFX principles. This paper is a preliminary investigation into how geometry can affect function and DFX attributes, in this case DFM (Design for Manufacturing).

In the ever increasing competitive market, manufacturers cannot survive if they cannot provide quality products at a suitable price [1]. In addition,

\* Corresponding author. A. Azizi

Email: [margazi@yahoo.com](mailto:margazi@yahoo.com)

Paper first received Aug.. 12, 2011, and in revised form Oct. 04, 2011.

companies are required to develop these high quality products within an ever shorter time frame. In order to achieve these challenging objectives, manufacturers turn to integrated CAD, CAM and CAE tools. [2]

Most of the attributes that are determined for product success are established in the product development phase. The attributes affect the manufacturing cost and overall product function i.e. quality.

The CAD/CAE/CAM technologies are modern design tools that facilitate reduction in product development time and cost as a result of improvement in productivity [3],[4]. Through the stages of design to manufacturing, less time is spent requesting clarification when 3D CAD solid models are used as compared to 2D CAD models [5].

The 3D CAD models, produced by the CAD software, can be analyzed by CAE computer and engineering software to detect design errors early in the design process [6]. The use of CAE in product development reduces the need for a large number of physical prototypes [7]. Ali et al has shown that CAE can help to predict structural behavior of designs in order to improve them, as in the case of cold-formed steel connections [8].

Applications of DFX have been shown to be beneficial to product development. Various DFX tools and methodologies address specific issues in the product life cycle. The use of DFMA (Design for Manufacture and Assembly) has been shown by Aplern to reduce manufacturing and assembly costs.[9]. Research has been done to integrate the benefits of DFX, such as DFMA, with CAD linked through a knowledge based system [10].

A better level of understanding of geometry, function and DFX principles and their interaction is needed to further advance the integration effort. This paper looks into a preliminary investigation that will serve as a start to developing an integrated methodology involving geometry, function and DFX principles through the use of CAD/CAE/CAM, which can be implemented through a knowledge based system in a CAD environment.

### 1-1. Literature Review

CAD/CAE/CAM has been used to improve production processes. Tufoi et al used CAD/CAE in the development of parts to improve the continuous casting process through the rapid design optimization and manufacture of parts. This resulted in reduced cost and time associated with the improvement of the continuous casting process [11] Al-Omari et al also applied CAD/CAM/CAM to improve the die forging process resulting in the reduction of tool development and lead time.

CAD software was used to create die forging parts using predetermined parameters. CAE software was used to simulate and optimize the forging process. CAM was then used to quick manufacture die moulds

[12] A RE/RP/CAD/CAE/CAM system was used in the development of a progressive sheet metal stamping for a magnesium cell phone cover, by Lin, and Kuo, which resulted in reduced process development cost and time, in addition to improved process quality.[13] Vinodh, Devadasan and Shankar in their research concluded that the CAD/CAE/CAM system can be employed as a tool to achieve agile manufacturing ability provided that management could be convinced of the benefits of CAD/CAE/CAM [14,] [15].

Vinodh et al focused on applications of CAD/CAE/CAM to achieve agility for an injection moulding process through design of component variants in CAD which were tested in specialized injection moulding simulation software to obtain manufacturing optimization, through selection of manufacturing parameters that enable agility [16]. Tufoi et al applied CAD/CAE/CAM technology to develop a gear system for a cement plant. In addition specialized CAD gear software was used in conjunction with standard CAD software to create the CAD models.

The CAE component of SolidWorks was used to optimize the design. CAM software was used in the development of tool parts to manufacture the gears for the gear system. Significant time and resource savings were achieved through the use of CAD/CAE/CAM technology for design optimization and part realization [17]. Bostan et al also applied CAD/CAE for the development of precessional gear drives to aid in geometric development and dynamic simulation of the gear drive [18].

Researchers have also employed techniques to improve the integration of CAD/CAE/CAM systems. Rahimic et al used a Visual C and common data software to integrate CAD (SolidWorks), CAE (CosmicWorks) and CAM (Solid CAM) to design test and manufacture screws for a complex assembly. The database contained shared data, required by the CAD/CAE/CAM system, such as dimension, material and tolerances [19]. Visual C and CAD (ProE) and CAE (ANSYS) software APIs were used by Aimin et al to improve the integration of a CAD/CAE system for the development of a truck mounded crane [20]. Park and Dang also used CAD and CAE software APIs in addition to common scripting and programming to improve CAD/CAE integration and facilitate automation of structural optimization using a RSM (Response Surface Methodology) or RBF (Radial Basis Function) to reduce the time and inaccuracy currently associated with manual structural optimization methods [21]. A mixed representation of solid models was developed using HLT (High Level Topology) by Hamri et al to improve the integration of CAD and CAE solid model robustness, and FEA model preparation [22]. Olumolade et al describes a proposed method of integration between CAD and CAM to improve the manufacturability of products through the use of prototypes.[23]

Hou, et al developed a special CAE system implementation of CAD software API for the development and optimization of auto body parts using a parametric template and data base. The system reduced the cost of the initial designs and aided the user in decision making during the concept design phase [24].

Similarly, SUV bumpers were optimized by Park and Jang through the use of parameters to improve the safety of SUV bumpers using the Taguchi optimization technique and Pugh selection matrix, which was validated using CAE [25].

Kuo Huang and Zhang discuss the importance of DFMA in product development in the reduction of development and manufacturing costs and time-to-market. They also indicated the growing trend to include DFE (Design for Environment) in product development. In addition Kuo Huang and Zhang concluded that the best way to implement DFX, after encountering managerial resistance and inter disciplinary team conflict, is through an intelligent expert system with an easy to use human interface [26]. Several researchers, among them Alkadi, as well as Selvaraj, Radhakrishnan, and Adithan, have begun to address various aspects of DFX.

Both research teams have used parameter part features and the integration mechanism [27] [28]. However, focus is still on integration of DFX methodology or tools as is the case of Alkadi DFER (Design For Every Reduction) in the product development process [27], whereas Selvaraj, Radhakrishnan, and Adithan integrate DFMA into the product development process via CAD [28].

Sy developed a database to assist the designer in incorporating design for environment issues in the product development process. The system combines the modelling of geometric, topological and environmental data to determine a products environmental impact throughout the life cycle. [29]. Bargekis, Mankute, and Cikotiene developed an integrated methodology involving CAD, "Design for Excellence" cost database and specialized equations to estimate product and process costs for new products, based on part standardization, geometry, material parameters and product complexity. [10]

To date, evidence of an integration methodology for function and geometry involving the use of two major DFX concepts such as DFMA and DFE combining CAD/CAE/CAM is yet to be found.

This paper is a preliminary investigation into developing such an integrated methodology with function represented by function attributes and geometry represented by model parameters for a test component. DFM concurrent Costing 23 Software of Boothroyd and Dewhurst will be used in identifying parameter effects on the component's manufacturing performance values. SolidWorks will determine function responses of the component to parameter

changes. The test component will be varied by parameters through a design table to generate 6 configuration/variants. These variants will then be subjected to a CAE test to determine the response at performance levels. The findings and future work will also be discussed.

## 2. Experimental Procedure

The experimental procedure used in this paper is shown in, in the appendix. In phase 1, *Function Development*, a concept is chosen and the functions to be investigated are determined. In phase 2, *Variant Development*, parameters are identified from concept dimensions. The concept is used to develop a 3D solid parametric model in a CAD software package (SolidWorks®). A design table is then used to quickly develop variants, from finalized parameters, prior to evaluation.

In phase 3, *Variant Evaluation*, the 3D solid model variants are tested in a FEA (Finite Element Analysis) package (SolidWorks Simulation®) with loading conditions and testing criteria established. In addition, CAD data, from the model variants, is imported into DFM concurrent costing®, which is a component of DFMA2009® (a Design for Manufacturing and Assembly software package from Boothroyd and Dewhurst), for a manufacturing cost analysis.

In phase 4, *Parameter Analysis*, the results from the CAE testing and DFM concurrent costing are compiled and parameter-to-function attributes plots are created and correlations determined. A correlation table is then developed and used to create correlation charts to determine the most influential parameters and most sensitive function and manufacturing attributes.

### 2-1. Function Development

In the *Function Development* phase, the concept to be used in the investigation is chosen. In this case, a part from a previous research exercise is used. After selecting the concept, the functions to be investigated are defined. In this case, the functions are limited to the responses to a given loading condition. The responses are stress, strain, displacement and factor-of-Safety (FOS). Other function attributes are also defined such as mass and volume. In addition, manufacturing attributes are also included and focus on the cost per part and the operation time. In all, eight functions are defined.

### 2-2. Variant Development

In phase 2, *Variant Development*, the concept preliminary parameters are identified with of the help of preliminary concept dimensions. This is followed by establishing preliminary parameters that govern concept features. The concept is then developed into a 3D parametric solid model using the preliminary parameter identified. In an actual product development process, the value of the preliminary parameters can be

obtained from target specifications and constraints. After the 3D solid model is created using CAD, the parameters to be used in the investigation are finalized. The final parameters are then used to create a design table, which is used to create model variants. The parameters of the model were varied to produce the model variants shown in the design table (Table 1), which is in the appendix.

The location of the parameters on the model is shown in Figures 2 and 3, which are present in the appendix. In all six model variants were created using the design table as shown in Figure 4. The design table, which is a tool found in SolidWorks®, can be used to quickly change and generate part variants. The design table is presented as an MS Excel® sheet with all of the capabilities of MS Excel®. Formulas can be used to establish geometric relationships between parameters.

Tab. 1. Design table used to develop variants

**Design Table for:  
Clamp Back**

Parameters	upper length	upper height	spine height	spine width	lower length	lower height	clamp thickness	hole diameter	hole centre distance	step height	outer face fillet
Variant A	37	6.35	90	12.7	31.2	12.7	12.7	6.35	12.7	4	4.85
Variant B	25	6.35	45	8	19.9	8	12.7	6.35	12.7	2	2.425
Variant C	37	8	135	15	31.2	15	12.7	6.35	12.7	4	6
Variant D	37	6.35	90	12.7	31.2	12.7	25.4	12.7	12.7	4	4.85
Variant E	37	8	90	15	31.2	12.7	12.7	6.35	12.7	2	4.85
Variant F	40.7	8.8	99	16.5	34.32	13.97	13.97	6.35	12.7	2	4.85

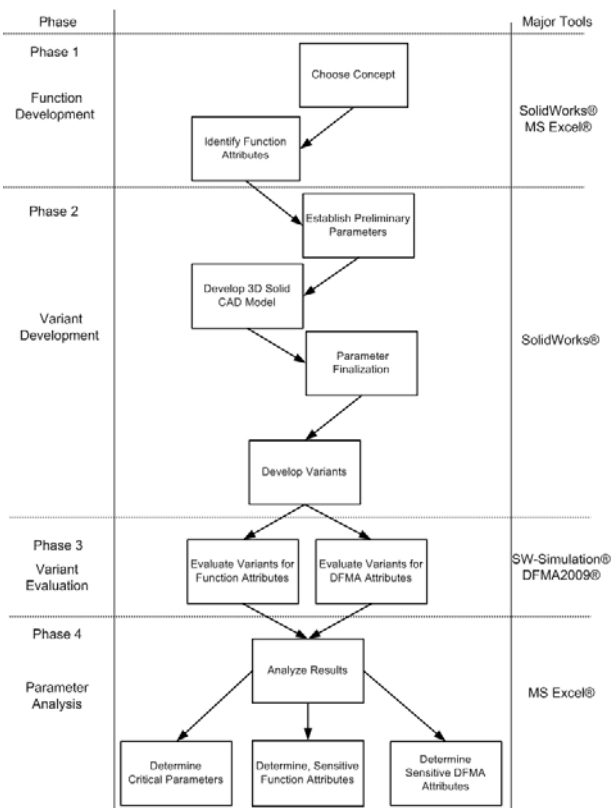

Fig. 1. Experimental Procedure

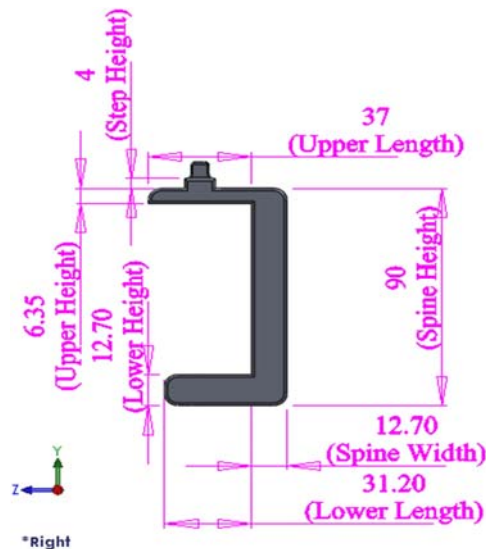

Fig. 2. Parameter location-right view

2-3. Variant Evaluation

The CAE testing of the variants was conducted using SolidWorks Simulation®, which is the finite element analysis component of SolidWorks®. The loading conditions were established from a previous research exercise. A static linear test was conducted on the six variants. The result plots were obtained for maximum stress, displacement, strain and Factor-of-Safety (FOS).

A sample of a distribution plot is shown in Figure 5. The original material used was 1060 Aluminum Alloy (having a yield strength of 27 N/mm<sup>2</sup>) A second set of tests was conducted with 1060 H18 Aluminum alloy (having a yield strength of 125 N/mm<sup>2</sup>), in order to compare the FOS results to the A1060 test set. The results of the CAE testing are shown in Table 2, in the appendix. The results of the CAE testing were placed into an MS Excel sheet for analysis. The manufacturing cost analysis was conducted using DFM concurrent costing from Boothroyd and Dewhurst. CAD data of each of the variants was imported into the DFM concurrent costing. Figure 6, located in the appendix, shows the use of the DFM concurrent costing software during cost analysis. A manufacturing cost analysis was done for each variant for two manufacturing processes, die casting and 5-axis CNC machining. Figure 7, in the appendix, shows a screen shot of one of the results produced by the DFM concurrent software. The results, located in Table 3 in the appendix, mainly total cost per part and operation time, were collected and placed in an MS Excel sheet for analysis.

**2-4. Parameter Analysis**

After CAE and DFM evaluation, the results were compiled into a results table which included the parameters varied. Parameter plots were created and the correlation obtained to determine if any relationship exists between the parameter variance and the function attributes associated with the model, such as stress, manufacturing cost etc. A sample of a parameter plot is shown in the appendix (Figure 8). A total of 63 parameter plots were created for the CAE testing results and 18 were created for the DFM cost analysis results.

A screen shot of the parameter plots created during the analysis of the CAE results is seen in the appendix (Figure 9).

The correlation values obtained from the parameter plots were collected into respective correlation tables for the CAE testing and DFM cost analysis. Parameter-to-Attribute and Attribute-to-Parameter correlation charts were created for both the CAE results and DFM results to help determine the most influential parameters and most sensitive attributes. A sample of two correlation charts is shown in Figure 10, located in the appendix.

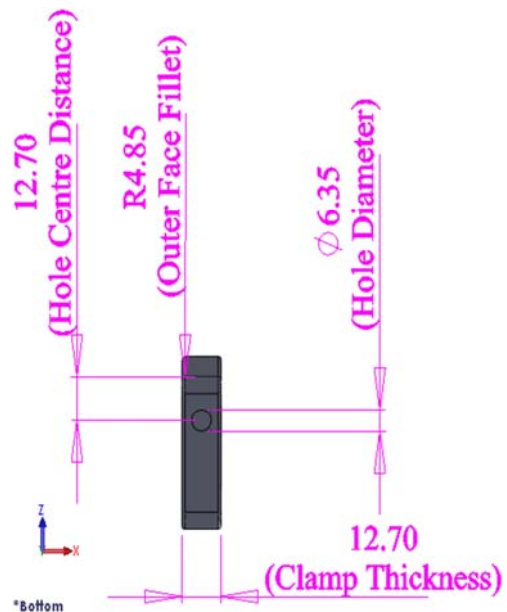

**Fig. 3. Parameter location-bottom view**

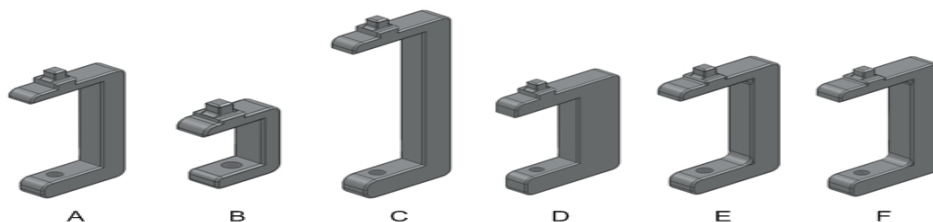

**Fig. 4. Model variants**

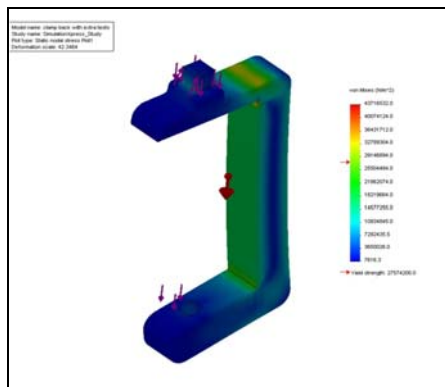

**Fig. 5. Stress Distribution of Variant A**

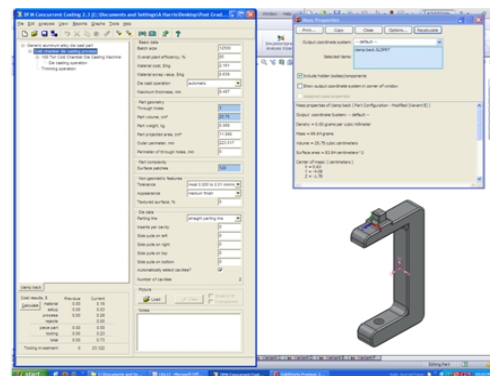

**Fig. 6. DFM Concurrent Costing in Use**



Tab. 2. Results of CAE testing

Variants	MAX VON:		MAX URES:		MAX ESTRN:		MIN FOS	MIN FOS	Mass [kg]	Volume [m <sup>3</sup> ]
	von Mises		Resultant		Equivalent					
	Stress [N/m <sup>2</sup> ]	Displacement [m]	Displacement [m]	Strain	A1060	A1060 H18				
Variant A	4.61E+07	2.78E-04	2.78E-04	4.85E-04	6.00E-01	2.70E+00	6.08E-02	2.25E-05		
Variant B	3.32E+07	9.92E-05	9.92E-05	3.65E-04	8.30E-01	3.80E+00	2.33E-02	8.61E-06		
Variant C	3.16E+07	3.19E-04	3.19E-04	3.11E-04	8.70E-01	3.82E+00	9.51E-02	3.52E-05		
Variant D	3.02E+07	5.88E-05	5.88E-05	2.15E-04	9.10E-01	5.31E+00	1.11E-01	4.12E-05		
Variant E	4.07E+07	1.82E-04	1.82E-04	3.82E-04	6.80E-01	3.10E+00	6.96E-02	2.57E-05		
Variant F	3.83E+07	1.76E-04	1.76E-04	4.10E-04	7.20E-01	3.30E+00	9.27E-02	3.43E-05		

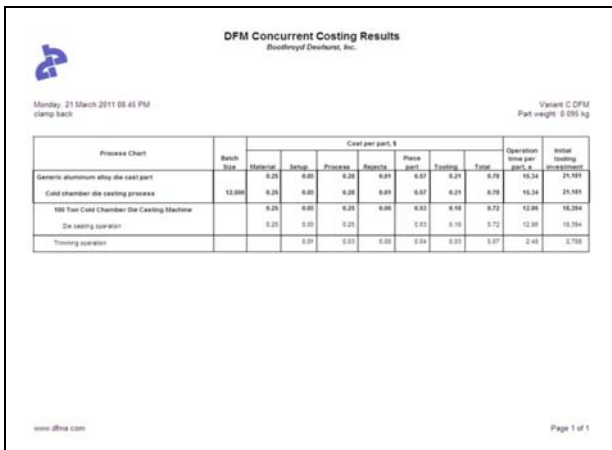

Fig. 7. Sample of DFM concurrent costing results

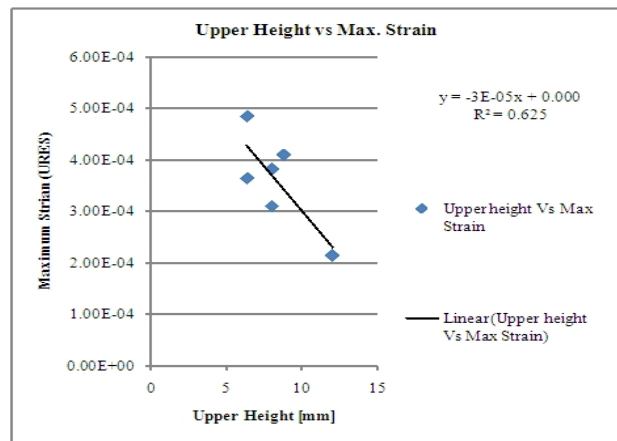

Fig. 8. A Parametric Plot for Upper Height

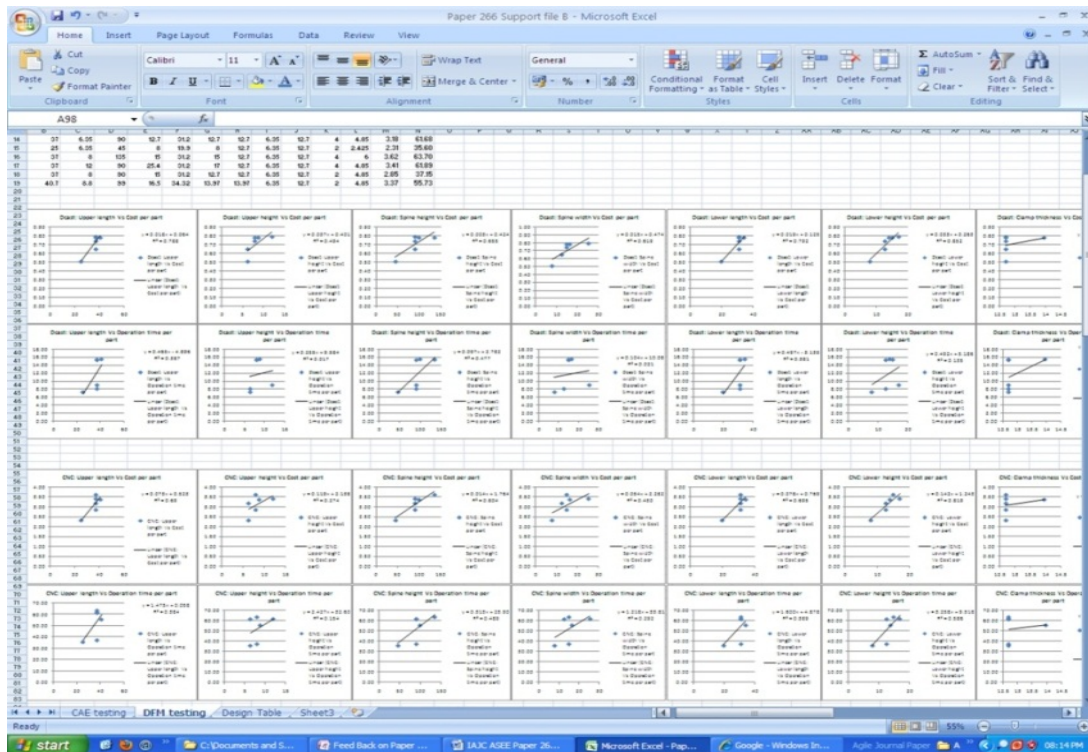

Fig. 9. Parametric plots created during CAE results analysis

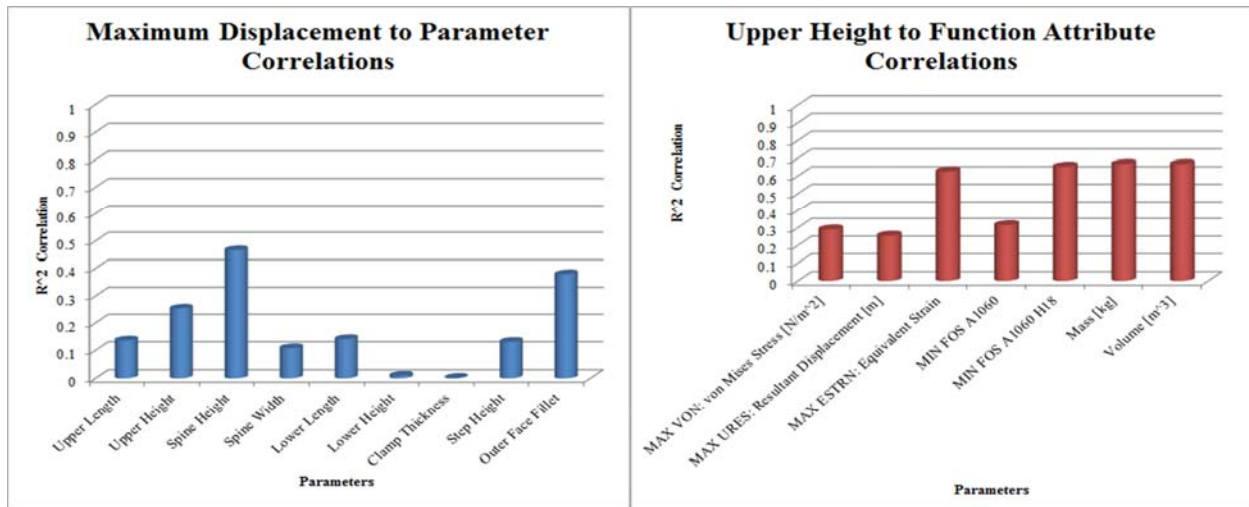

Fig. 10. Correlation charts

Tab. 3. Results of DFM concurrent costing

Variants	Functions	Die Casting		CNC Machining	
		Total Cost per part, \$	Operation time per part, s	Total Cost per part, \$	Operation time per part, s
Variant A		0.65	7.99	3.18	61.68
Variant B		0.51	7.18	2.31	35.60
Variant C		0.78	15.34	3.62	63.70
Variant D		0.79	8.94	3.41	61.89
Variant E		0.74	15.26	2.85	37.15
Variant F		0.78	15.46	3.37	55.73

For CAE testing, the *Upper Height* parameter was the most influential, followed by the *Spine Width* and *Lower Height* parameters. Mass was the most affected function attribute. Parameters had a greater effect on a harder Aluminum (A1060 H18) as compared to a softer Aluminum (A1060). The maximum stress was the least affected by the parameters. Overall, non-geometric parameters had more influence on stress than geometric parameters.

For DFM costing, the *Upper Length* parameter, had the most influence on the die casting process, while the *Lower Height* parameter had the most influence on the CNC machining process. On the whole, parameters had a greater effect on part than on operation time for both manufacturing processes. In addition, parameters had a greater effect on the “cost per part,” attribute as compared to CNC machining.

The case is opposite for “operation time” attribute, where the parameters had a higher effect for CNC machining than on die casting. Generally, the CNC machining process was more affected by the parameters than the die casting process.

### 3. Discussion

The parameter analysis can be useful in the product development process by identifying critical parameters associated with the design. In turn, the designer can address such parameters in order to achieve target design specifications and DFX requirements. In this case only DFM was included in the preliminary investigation. The functions defined were primarily associated with the ‘strength’ of the concept under a loading condition.

This type of investigation can be expanded to include more DFX components, such as DFA and DFE. In addition other functions associated with solution principles can also be investigated. In general, this investigation showed that the parameters, which were primarily geometric, had less of an effect on the defined function than expected. This may be due to the fact that the functions investigated were associated with material properties. A more comprehensive investigation can include more functions associated with solution principles and a wider range of material used during CAE testing.

This type of investigation can be used to develop a more feature-based DFX toolset that can be later incorporated into a CAD-based system. A simpler model is better in helping to identify relationships between geometry and any DFX attributes of the model or concept rather than a relatively complex part used in this preliminary investigation.

In addition, more variants will have to be used during the evaluation phase of the investigation. Six variants will be insufficient to establish any relationships between geometry, functions and DFX attributes with any confidence. In addition, more manufacturing processes will have to be included in future investigations in order to provide a broader understanding of the effect parameters can have on manufacturing attributes. Physical testing will have to be conducted to confirm any relationships identified. Automation of the methodology can be considered in helping to speed up the investigation process especially when functions associated with solution principles are involved.

#### 4. Conclusion

This paper describes the preliminary investigation of geometry and its influence on function and DFM through the use of CAD/CAE. This is a step in the early stage of research involving a more comprehensive investigation into geometry and function relationships involving DFX through the use of CAD/CAE/CAM. The purpose is to develop an integrated methodology to aid designers in developing discrete products with better quality in a shorter time frame. This investigation has shown that geometric-based parameters have less of an effect on function associated with materials than expected. The investigation has also shown that the same set of parameters can affect different manufacturing processes in different ways. Future research will entail expanding the functions and DFX principles involved. Later on, automation will be considered to help speed up the investigation process.

#### References

- [1] Kumar, M.S., Islam, M.N., Lenin, N., Kumar V.D., "Optimum Tolerance Synthesis for Complex Assembly with Alternative Process Selection Using Bottom Curve Follower Approach," International Journal of Engineering, Vol. 3, No. 4, 2009, pp. 380-402.
- [2] Ali, F., Chowdary, B.V., Imbert, C.A.C., "Part Design and Evaluation Through Reverse Engineering Approach," International Journal of Agile Manufacturing, Vol. 11, No. 1, 2009, pp. 73-82.
- [3] Pahl, G., Beitz, W., Engineering Design, The Design Council, London, 1984.
- [4] Shetty, D., Design for Product Success, Society of Manufacturing Engineers, Dearborn, 2002.
- [5] Haftl, L., "3D CAD Has Become a Must Have," American Machinist, Vol. 151, No. 4, 2007, pp. 26-28.
- [6] Shetty, D., "Advances in Product Design: Innovative Approaches" IEM-2006 Conference on Building Engineering and Management Competence; June 1-2, 2006, pp. 22-30.
- [7] Thilmany, J., "CAD Meets CAE," Mechanical Engineering, Vol. 121, No. 10, 1999, pp. 66-69.
- [8] Ali, B.A., Saad, S., Osman, M.H., Ahmad, Y., "Finite Element Analysis of Cold- Formed Steel Connections," International Journal of Engineering, Vol. 5, No. 2, 2011, pp. 185-193.
- [9] Alpern, P.B., "Trimming Cost at the Design Stage," American Machinist, Vol. 153, No. 1, 2009, pp. 38-39.
- [10] Bargekis, A., Mankute, R., Cikotiene, D., "Integrated Knowledge-Based Model of Innovative Product and Process Development," Estonian Journal of Engineering, Vol. 15, No.1, 2009, pp. 13-23.
- [11] Tufoi, M., Vela, I., Marta, C., Tută, A.I., "Studies Regarding Design and Optimization of Mechanisms Using Modern Techniques of CAD and CAE," Analele Universitatii "Eftimie Murgu, Vol. 17, No. 1, 2010, pp. 191-202.
- [12] Al-Omari, F., Al-Jarrah, M., Omari, M., Hayajneh, M., "Development of a CAD/CAM System for Simulating Closed Forging Process using Finite-Element Method," Engineering Computations, Vol. 26, No. 3, 2009, pp. 302-312.
- [13] Lin, B-T., Kuo, C-C., "Application of an Integrated RE/RP/CAD/CAE/CAM System for Magnesium Alloy Shell of Mobile phone," Journal of Materials Processing Technology, Vol. 209, No. 6, 2009, pp. 2818-2830.
- [14] Vinodh, S., Devadasan, S.R., Shankar, C., "Design Agility Through Computer Aided Design," Journal of Engineering Design and Technology, Vol. 8, No. 1, 2010, pp. 94-106.
- [15] Vinodh, S., Sundararaj, G., Devadasan, S.R., Kuttalingam, D., Rajanayagam, D., "Agility Through Rapid Prototyping Technology in a Manufacturing Environment using a 3D Printer," Journal of Manufacturing Technology Management, Vol. 20, No. 7, 2009, pp. 1023-1041.
- [16] Vinodh, S., Sundaranj, G., Devedasan, S.R., Kuttalingam, D., Rajanayagam, D., "Achieving Agility in Manufacturing Through Finite Element Mould Analysis: An Application - Oriented Research," Journal of Manufacturing Technology Management, Vol. 21, No. 5, 2010, pp. 604-623.
- [17] Tufoi, M., Vela, I., Marta, C., Mituletu, C., Amariei, D., Stroia, M-D., "Design, Optimization and Realization of Mechanical Parts Using CAD, CAE-AND-CAM Techniques," Annals of DAAAM & Proceedings, Vol. 21, No. 1, 2010, pp. 799-800.



- [18] Bostan, I., Dulgheru V., Sochireanu, A., "Cae Development of Processional Drives Using Autodesk Inventor Platform," *Fiability & Durability / Fiabilitate si Durabilitate*, No. 1, 2010, pp. 121-126.
- [19] Rahimic, S., Visekruna, V., Edin, S., "Integration CAD-CAE-CAM Trough Database for Complex Assemble," *Annals of DAAAM & Proceedings*, Vol. 20, No. 1, 2009, pp. 1389-1390.
- [20] Aimin J., Qian; W., Quansheng, H., Libin, S., Hua, Z., Zhengming, C., "The Case-Based Rapid Design System for Telescopic Boom," *ICIC 2010 - 3rd International Conference on Information and Computing*, Vol. 3, 2010, pp. 265-268.
- [21] Park, H-S., Dang, X-P., "Structural Optimization Based on CAD-CAE Integration and Metamodeling Techniques," *Computer-Aided Design*, Vol. 42, No. 10, October 2010, pp. 889-902.
- [22] Hamri, O., Léon, J.C., Giannini, F., Falcidieno, B., "Computer Aided Design and Finite Element Simulation Consistency," *Strojnicki Vestnik/Journal of Mechanical Engineering*, Vol. 56, No. 11, 2010, pp. 728-743.
- [23] Olumolade, M., Chen, D.M., Chen, H., "Design Prototyping for Manufacturability," *International Journal of Modern Engineering*, Vol. 10, No. 2, 2010, pp. 5-9.
- [24] Hou, W.B., Zhang, H.Z., Chi, R.F., Hu, P., "Development of an Intelligent CAE System for Auto-Body Concept Design," *International Journal of Automotive Technology*, Vol. 10, No. 2, 2009, pp. 175-180.
- [25] Park, D.K., Jang, C.D., "Optimum SUV Bumper System Design Considering Pedestrian Performance," *International Journal of Automotive Technology*, Vol. 11, No. 6, December 2010, pp. 819-824.
- [26] Kuo, T-C., Huang, S.H., Zhang, H-C., "Design for Manufacture and Design for 'X': Concepts, Applications, and Perspectives," *Computers & Industrial Engineering*, Vol. 41, No. 3, December 2001, pp. 241-260.
- [27] Alkadi, N.M., "Product Design for Energy Reduction in Concurrent Engineering: An Inverted Pyramid Approach," PhD. Dissertation, Department of Industrial and Management Systems Engineering West Virginia University, 2007.
- [28] Selvaraj, P., Radhakrishnan, P., Adithan, M., "Integrated Approach to Design for Manufacturing and Assembly Based on Reduction of Product Development Time and Cost," *The International Journal of Advanced Manufacturing Technology*, Vol. 42, No. 1-2, 2009, pp. 13-29.
- [29] Sy, M., "Integration Des Caracteristiques de Cycle de Vie Dans la Phase De Conception," PhD. Dissertation, Department of Mechanical Engineering. Ecole Polytechnique, Montreal (Canada), 2008.

