



Proposing a Model for Evaluating Gate Valve Cover Manufacturing Methods by Value Engineering and Data Envelopment Analysis Approaches with a Case Study in Petro Tajhiz-e-Sepahan Company

M. Ziaei and M. Farahmand and M. Karbasian

M. Ziaei and M. Farahmand *Department of Industrial engineering, Najafabad Branch, Islamic Azad University, Najafabad, Iran.*

M. Karbasian *Department of Industrial Engineering, Malek Ashtar University of Technology, Isfahan, Iran.*

KEYWORDS

Efficiency evaluation, Data Envelopment Analysis (DEA), decision-making index, TOPSIS, Value engineering, Gate valve cover

ABSTRACT

This research aims at presenting a consolidated model of data envelopment analysis (DEA) technique and value engineering to select the best manufacturing methods for gate valve covers and ranking the methods using TOPSIS. To do so, efficiency evaluation indices were selected based on the value engineering approach and different manufacturing methods were evaluated using DEA technique. Finally, effective methods were ranked based on TOPSIS. Accordingly, 48 different methods were identified for manufacturing the part. The DEA results showed that only 12 methods have complete efficiency. Meanwhile manufacturing method No. 32 (A216 WCB casting purchased from Chinese market as the raw material, machining by CNC+NC and drilling by radial drill) was ranked the first. Major limitations of the research include time limitations, place limitation, lack of access to the standards adaptability index in different machining and drilling methods, limitation on evaluating all parts of a product, limitation on a technique evaluating efficiency and ranking, and mere satisfying with superior indices in each factor of value engineering. Most previous studies only evaluated efficiency of manufacturing methods based on a single approach. By applying value engineering, which is in fact a combination of three approaches (including quality approach, functional, and cost approaches), the present research provided a far more comprehensive model to evaluate manufacturing methods in industrial.

© 2015 IUST Publication, IJIEPR, Vol. 26, No. 2, All Rights Reserved.

1. Introduction

Energy resources are considered as the major national capitals of each country. Meanwhile, fossil fuels are of the rarest energy resources

for which correct and optimal use plays a crucial role in dynamics and improvement of countries. This issue doubles attention to the equipment related to energy resources. Focusing on gate oil valve as one of the oil and gas control equipment, this article studies different manufacturing methods of its cover.

* Corresponding author: M. Karbasian
Email: mkarbasi@mut-es.ac.ir

This is performed in Petro Tadjiz-e-Sepahan Company, which is one of the biggest manufacturers of oil and gas valves with the greatest share in Iranian market. Today, due to the competitive atmosphere dominant over manufacturing organizations, manufacturing products with lowest cost, highest quality, and within the shortest manufacturing time cycle has been of paramount importance (Theodorou & Florou, 2008). The prerequisite to access such features is to make effective decisions at strategic and operational levels in order to select the best method to manufacture an organization's products and improve its overall performance (Chen *et al.*, 2006; Due *et al.*, 2010). Alternative manufacturing methods create more effective methods to perform affairs. Therefore, they provide conditions to improve quality of goods, services, and productivity, reduce time needed to supply of new products to market, and satisfy endless requirements of humans. Therefore, strategies, decision-making, and measures of an organization or a company to evaluate and modify production methods form the core of its economic-social development. In case an organization is able to direct this process in a targeted manner, it will undoubtedly pave the way for continuous success and development and will hope to survive in the competitive and turbulent of the world's today (Ansari and Zare, 2009).

Evidently, scientific and authentic methods should be used for evaluating different manufacturing method and recognizing a superior method. This way, the results obtained for making decisions, modifying, and improving approaches will be reliable. One of the major reasons of failure of evaluation programs in organizations is application of mental and non-scientific and inappropriate methods to measure performance at different levels of an organization. Therefore, an appropriate, applicable, and reliable technique should be selected to measure performance with respect to the main objective of measuring efficiency in proportion to the problem facing an organization and the involved variables (Avkiran & Parker, 2010).

Performance evaluation has gained attentions since management classic theories were discussed. DEA is one of the techniques applied most in performance measurement field (Charnses *et al.*, 1978). The main idea in forming DEA is to provide a technique through which one is able to identify the units with the best performance (efficient units) and measure efficiency level of other units (inefficient units) among a set of similar units. This is performed with respect to input and output values of each unit (Cook and Seiford, 2009). It should be noted that several methods and models have been proposed so far; regression method, SFA, FDH are among them. DEA methodology, due to its various applications such as separation of effective and ineffective units in a system, determining efficiency score, comparing and modeling, ranking and evaluating efficiency over the time, are considered as the methods applied more than other performance measurement techniques. Whereas, other methods discussed in performance measurement field did not proposed such various performances (Gattoufi *et al.*, 2004 and Avkiran & Parker, 2010).

In addition to the efficiency-related measurements, application of value engineering is of the most efficient management tools to create competitive advantage for an organization. Through reducing rework and replacing lower cost methods, value engineering attempts to help an organization to achieve its goals (Seddigh *et al.*, 2009). This study leads to finding different ways for manufacturing products or providing services. A method that provides the relevant performance with lower cost and better quality is selected among these different methods. According to the definitions, *function*, *quality*, and *cost* are the three major components of value. The components can be interpreted in the following relation (Haji Zeinolabedini, 2006; Dell'Isola, 2009).

$$\text{Value} = \frac{\text{Function} + \text{Quality}}{\text{Cost}} \quad (1)$$

This research evaluates different methods of manufacturing gate valve cover. Many studies have been conducted and several method and models have been employed to evaluate

different manufacturing methods and select their most efficient ones in industrial assemblies. For instance, scoring models, break-even point approach, fiscal estimate traditional methods, the AHP, and

simulation of production lines. Table 1 shows major studies in this file along with their applied techniques, research objectives, the number of studied manufacturing methods and their overall approach.

Tab. 1. The Studies to Evaluate Different Manufacturing Methods

Researchers and Year of Study	Technique Used for Evaluating Different Manufacturing Methods	Main Purpose of Research	Number of the Manufacturing Methods	Used Indices or Approaches
Yusuff <i>et al.</i> (2001)		Predicting a Superior Method	2	Organizational Culture
Punniyamorthy and Ragavan (2003)		Selecting a Superior Method	2	Time and Cost
Mohandy and Deshmukh (1998)	Analytic Hierarchy Process (AHP)	Selecting a Superior Method	3	Knowledge Management
Oeltjenbruns <i>et al.</i> (1995)		Selecting a Superior Method	6	Economic and Technological
Datta <i>et al.</i> (1992)		Justifying a Superior Method	5	Economic
Chan <i>et al.</i> (2005)	Fuzzy Analytic Hierarchy Process (FAHP)	Selecting a Superior Method	3	Operational Cost, Efficiency, etc
Orr (2003)	Fiscal Estimate Traditional Methods	Evaluating Available Methods	3	Fiscal
Talluri <i>et al.</i> (2000)	Data Envelopment Analysis (DEA) Technique	Selecting a Superior Method	13	Functional
Talluri and Yoon (2000)		Selecting a Superior Method	12	Functional
Verter and Dasci (2002)	Mixed-Integer Nonlinear Programming	Manufacturing Programming	1	Cost
Bokhorst <i>et al.</i> (2002)		Selecting Superior Method	2	Profitability
Diaz <i>et al.</i> (2003)	Group Analysis Technique	Inspecting Available Methods	20	Organizational Prosperity
Chen and Small (1994)	Integrated Planning Models	Manufacturing Programming	12	Planning-Managing
Efstathiades <i>et al.</i> (2002)		Manufacturing Programming	1	Planning

In spite of having many advantages, all the presented models have some disadvantages to evaluate manufacturing methods in industrial assemblies, they do not allow to offer a complete and comprehensive approach in inclusive evaluation of different manufacturing methods and select the most effective one (Chang and Wang, 2009). On the other hand, Table (1) shows that most previous studies only discussed efficiency of the manufacturing methods based on one approach. However, by applying VE that is in fact a combination of three approaches (including quality approach, functional, and cost approaches), the present study presents a far more comprehensive and completed model.

This article identifies different manufacturing methods of gate valve cover. Key indices are

then selected to choose the superior method with respect to VE approach. By applying the available documents and reviewing records, data of any index in each manufacturing method are collected. The effective methods are then selected using data envelopment analysis and DEA Frontier software. The research is then discusses ranking of effective methods using TOPSIS.

2. Research Methodology

This article evaluated different manufacturing methods of gate valve cover. To do so, the first step was to select efficiency evaluation indices, which was performed with respect to VE. To do so, major indices used for measuring efficiency in manufacturing environment were categorized using authentic scientific references of census within three

main components of VE, i.e. *quality*, *cost*, and *performance*. Table 2 shows the results. After preparing a questionnaire using the 9-point Likert scale, the indices were evaluated by the office staff of Petro Tadjiz-e-Sepahan Company and its two subsidiaries 'Ebtakar Casting' and 'RanginZob'.

Superior indices of each component with higher mean value were selected with respect to the numerical results obtained from the questionnaires and according to the opinion of

an organization's senior management. Based on this, following variables were recognized as the superior important variables in measuring efficiency of different methods of manufacturing gate valve cover.

- 1) The standards adaptability index among 4 indices in quality component
- 2) Variables of material cost and labor cost among 12 indices in the cost component
- 3) Variable of number of output product from 8 indices of function component.

Tab. 2. Major Indices Used for Evaluating Efficiency of Industrial Assemblies

Value Engineering Components	Dimensions	References
Quality	Reliability	Jiang <i>et al.</i> 2011-Tuzakaya <i>et al.</i> 2011-Shehabuddeen <i>et al.</i> 2006-Kengpol & O'Brien, 2001- Vickery <i>et al.</i> 1997-Al Subaie, 2007
	Customer satisfaction	Cordero <i>et al.</i> 2005-Laihonen <i>et al.</i> 2012-Hofmann & Orr, 2005
	Adaptability (Conformance to specifications)	Chan <i>et al.</i> 2006-tuzkaya <i>et al.</i> 2011-Vickery <i>et al.</i> 1997-Stock & McDermott, 2001
	Consistency	Chan <i>et al.</i> 2006-stock & McDermott. 2001-Efstathiades <i>et al.</i> 2002
Cost	Labor Cost	Chan <i>et al.</i> 2006-folgado <i>et al.</i> 2010-Karsak & Kuzgunkaya 2002
	Material Cost	Chan <i>et al.</i> 2006-Folgado <i>et al.</i> 2010-Karsak & Kuzgunkaya 2002-Mohanty & Deshmukh 1998-Pecas <i>et al.</i> 2009-Bokhorst <i>et al.</i> 2002
	Machine Breakdown Cost	Chan <i>et al.</i> 2006-Bokhorst <i>et al.</i> 2002-Efstathiades <i>et al.</i> 2002-Sarkis 1999-Jiang <i>et al.</i> 2006
	Rework/Scrap	Chan <i>et al.</i> 2006
	Transportation	Chan <i>et al.</i> 2006-Verter, 2002-Bokhorst <i>et al.</i> 2002
	Inventory Cost	Chan <i>et al.</i> 2006-karsak & Kuzgunkaya 2002-Bokhorst <i>et al.</i> 2002-stock & McDermott, 2001
	Required Floor Space	Chuu 2009-Karsak & Kuzgunkaya 2002-Tuzkaya <i>et al.</i> 2011-Efstathiades <i>et al.</i> 2002
	Energetic Cost	Folgado <i>et al.</i> 2010-Tuzkaya <i>et al.</i> 2011-Pecas <i>et al.</i> 2009-Al Subaie 2007
	Setup Cost	Karsak & Kuzgunkaya 2002-Verter. 2002-Bokhorst <i>et al.</i> 2002-Hofmann & Orr. 2005
	Maintenance Cost	Chan <i>et al.</i> 2006-Karsak & Kuzgunkaya 2002-Faroq & O'Brien, 2009
Function	Delivery Time	Chan <i>et al.</i> 2006-Vickery <i>et al.</i> 1997-Stock & McDermott, 2001
	Market Responsiveness	Chan <i>et al.</i> 2006-Karsak & Kuzgunkaya 2002
	Speed to Complete Manufacturing Orders (No. of Output)	Chan <i>et al.</i> 2006-Stock & McDermott, 2001
	High Rate of Return	Chan <i>et al.</i> 2006-cordero <i>et al.</i> 2005-Schuh <i>et al.</i> 2012-Chuu 2009-Tuzkaya <i>et al.</i> 2011-Kengpol & O'Brien. 2001-Faroq & O'Brien, 2009-Bokhorst <i>et al.</i> 2002-Stock & McDermott, 2001-Hofmann & Orr, 2005
	Flexibility	Chan <i>et al.</i> 2006-Chuu 2009-Vickery <i>et al.</i> 1997-Schuh <i>et al.</i> 2012-Efstathiades <i>et al.</i> 2002-Cordero <i>et al.</i> 2005-Mohantv & Deshmukh 1998
	Learning	Chuu 2009-Laihonen <i>et al.</i> 2012
	Compatibility with Existing Machine	Chan <i>et al.</i> 2006-Shehabuddeen <i>et al.</i> 2006

After identifying superior indices in evaluating different methods of

manufacturing gate valve cover, it is necessary to divide the indices into two

groups of inputs and outputs to employ DEA technique.

Regarding Relation (1) and the fact that the goal of each organization is to gain further value in manufacturing its products and services, it attempts to promote quality and function and reduce existing costs. Therefore, indices of two components of quality and function are considered as the outputs of DEA technique that an organization attempts to maximize them. Indices of cost component are considered as inputs of the technique that an organization attempts to minimize them.

On the other hand, as per the opinion of an organization's senior management in all manufacturing methods, cost indices are factors to create relevant function and move toward favorable quality. Based on this, the standards adaptability indices and number of the output product of each manufacturing method are considered as the outputs and material cost indices and labor cost are considered as the inputs of DEA technique. Figure (1) shows final model of DEA, which indicates inputs and outputs

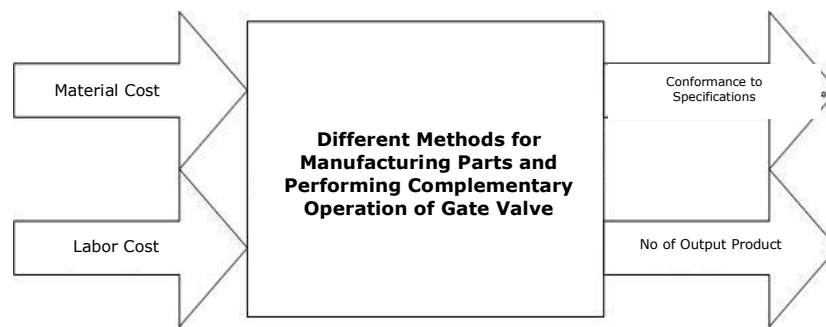

Fig. 1. Proposed DEA Model

Explanation of the proposed model to solve a problem is performed with respect to its input-oriented or output-oriented and type of its return to scale. As per the opinion of an organization's senior management, number of the output product of each method in unit of time and its adaptability to quality standards are the indices, which are not controlled adequately. In other words, the numerical values of output indices are known and predetermined. On the other hand, as each manufacturing organization aims to reduce manufacturing costs to achieve a higher level of profitability and emphasis of an organization's senior management on further control over cost factors as an input of DEA, the input-oriented model was considered for solving the problem. With respect to the manufacturing records and opinion of the senior management and office staff, the organization units are not acting on an optimal scale. That is, increasing material and labor costs may not proportionally lead to increasing output factors. Therefore, type of

return to scale was considered variable. In this mode, the use of BCC model - as a model with variable return to scale - was proposed at an input-oriented mode for solving the problem.

3. Case Study and Findings

Decision-making unit² is an organization or an entity that converts inputs into outputs and its performance evaluation is considered (Cooper *et al*, 2008). Here, the researcher attempts to evaluate performance of new manufacturing methods of gate valve cover in Petro Tadjhiz-e-Sepahan Company. The company was established in 2004 aiming at procuring required parts and equipment of industrial projects. As the company uses capital of private sector, profitability is one of its major goals. To obtain the profitability considered by shareholders, the company needs to have an optimal method in manufacturing its products. Gate valve, as one

² Decision-Making Unit- DMU

of the major products of Petro Tadjiz-e-Sepahan Company, is one of the types of frequently used industrial valves in oil, gas and petrochemical industries. Each valve has a disk with linear motion, which is used to start or cut flow. Reviewing exploded view drawings and considering the opinion of company's senior management, 4 parts including body, cover, seat and disk, and stem were identified as the main components of a valve. This research aims at identifying different manufacturing methods of cover and distinguishing effective and ineffective

methods. Cover is the second boundary of the main pressure on a valve, which is connected to the body by spot welding. Covers are the major part of main cost of an oil valve and also the main source of leakage. Different manufacturing methods of this part can be identified based on type of the material used for manufacturing cover, its method and machining tools, and drilling operation method. Different parts of gate valve can be seen in Figure (2).

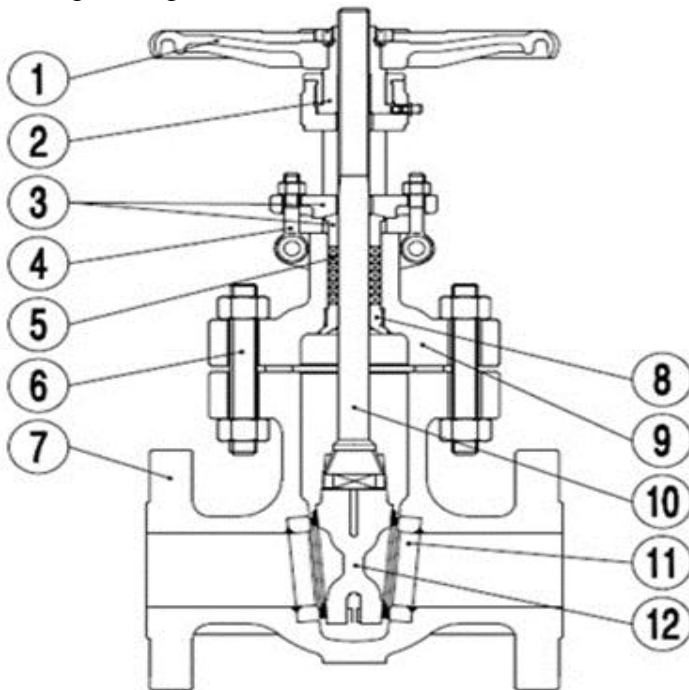

IT.	DESCRIPTION
1	HANDWHEEL
2	YOKE SLEEVE
3	GLAND FLANGE
4	GLAND EYE BOLT
5	PACKING
6	BONNET BOLT
7	BODY
8	COVER
9	BACK SEAT
10	STEM
11	SEAT
12	WEDGE

Fig. 2. Gate Valve Bill of Material

Three types of materials can be used for manufacturing covers. Based on the type of material, weight and cost of the parts will be different. In case A216 WCB casting, A350 LF2 casting and A105 forge are used for manufacturing cover, the parts will be 18, 15 and 28 Kgs, respectively. On the other hand, each type of material imposes a different charge on an organization. Reviewing order and purchase forms shows that each kilo of A216 WCB casting from Iranian market and Chinese market will cost the company 5400 Toman and \$1.6, respectively. With respect to the rate of exchange of 3000 Toman, 25 percent of customs charges, and 13 percent for releasing goods from customs and

transportation cost to company site, it will be 4500 Toman per kilo. The rate for purchasing A350LF2 casting from Iranian market and Chinese market will be 5700 Toman and 1.13\$ (equal to 4800 Toman). The rate for purchasing A105 forge from Iranian market and Chinese market will be 4400 Toman and 0.82\$ (equal to 3500 Toman), respectively. Moreover, making decision on type of material affects its adaptability index qualitative standards. The reason is that each type of the purchased material is analyzed by QC department and percentages of its components are adapted to the permissible percentages of each element in the standard. In case the contents of each element are within the ranges specified by the standard,

the *Accept* square is ticked; otherwise, *Reject* square is ticked. Number of the ticks in *Accept* squares exceeded all the ticks, which shows percentage of its adaptability with the standard. Based on this, A216 WCB castings purchased from Iranian market and Chinese market show 95 and 98 percent adaptability, respectively. This figure for A350 LF2 casting purchased from Iranian market and Chinese market equals 90 percent and 98 percent, respectively. The figure for A105 forge purchased from Iranian market and Chinese market equals 93 percent and 98 percent, respectively.

Machining operation of cover can also be performed using 4 different methods whose duration will be different with respect to the selected method and type of material. Reviewing of timing forms of the planning department shows that machining operation durations for covers using an NC lathe with jigs and fixtures, NC lathe without jigs and fixtures, NC drilling machine and NC+CNC lathe for material of A216 WCB casting are

1.25, 1.5, 1.5, and 1 hours, respectively. Machining operation durations for A350 LF2 are 1.75, 2.25, 2.25, and 1.1 hours, respectively. Machining operation durations for A105 raw material are 2.5, 3, 3, and 2 hours, respectively. Based on the salary and wages forms of financial department, man/hour cost of an NC lathe with jigs and fixtures and an NC without jigs and fixtures equals 15,500 Toman. Man/hour cost of an NC drilling machine and NC+CNC lathe equals 20,000 Toman.

Finally, drilling operation of covers can be performed by 2 different methods. Reviewing the timing forms of the planning department shows that durations of cover drilling operation using pillar drill and radial drill equal 1.9 and 1.2 hours, respectively. Based on the salary and wages forms of financial department, man/hour costs of a pillar drill and radial drill equals 80,000 and 8500 Toman, respectively. Table 3 shows numerical data of different methods for manufacturing gate valve covers.

Tab. 3. Numerical Data of Different Methods for Manufacturing Gate Valve Covers

Production Steps of Cover												
Manu factur ing Meth od	Material	We igh t (kg)	Cost Per kilogra m (in Toman)	Total Cost (in Toma n)	Standard Adaptabi lity	Machini ng	Machini ng Time (hour)	Labor Cost (Man/ho ur)	Labor Cost (in Toma n)	Drilli ng Time (hour)	Labor Cost (man/hou r)	Lab or Cost
1.	A216WCB casting purchased from Iran					NC Lathe with Jigs and Fixtures	1.25	15500	1937 5	Pillar drill		
2.	A216WCB casting purchased from Iran		5400	97200	0.95	NC Lathe without Jigs and Fixtures	1.5	15500	2325 0	Pillar drill		
3.	A216WCB casting purchased from Iran					NC Drilling	1.5	20000	3000 0	Pillar drill		
4.	A216WCB casting purchased from Iran					CNC+N C	1	20000	2000 0	Pillar drill		
5.	A216WCB casting purchased from abroad	8				Drilling NC Lathe with Jigs and Fixtures	1.25	15500	1937 5	Pillar drill	1.09	8000
6.	A216WCB casting purchased from abroad		4500	81000	0.98	NC Lathe without Jigs and Fixtures	1.5	15500	2325 0	Pillar drill		
7.	A216WCB casting purchased from abroad					NC Drilling	1.5	20000	2000 0	Pillar drill		
8.	A216WCB casting purchased from abroad					CNC+N C	1	20000	2000	Pillar drill		
9.	A350LF2 casting purchased	15	57000	85500	0.9	Drilling NC	1.75	15500	2712	Pillar		152 00

	from Iran				Lathe with Jigs and Fixtures NC			5	drill				
10.	A350LF2 casting purchased from Iran				Lathe without Jigs and Fixtures NC	2.25	15500	34875	Pillar drill				
11.	A350LF2 casting purchased from Iran				Drilling CNC+N C	2.25	20000	45000	Pillar drill				
12.	A350LF2 casting purchased from Iran				Drilling NC	1.1	20000	22000	Pillar drill				
13.	A350LF2 casting purchased from Abroad				Lathe with Jigs and Fixtures NC	2.5	15500	38750	Pillar drill				
14.	A350LF2 casting purchased from Abroad	4400	123200	0.93	Lathe without Jigs and Fixtures NC	3	15500	46500	Pillar drill				
15.	A350LF2 casting purchased from Abroad				Drilling CNC+N C	3	20000	60000	Pillar drill				
16.	A350LF2 casting purchased from Abroad				Drilling NC	2	20000	40000	Pillar drill				
17.	A105 forge purchased from Iran				Lathe with Jigs and Fixtures NC	2.5	15500	38750	Pillar drill				
18.	A105 forge purchased from Iran		123200	0.93	Lathe without Jigs and Fixtures NC	3	15500	46500	Pillar drill				
19.	A105 forge purchased from Iran				Drilling CNC+N C	2	20000	60000	Pillar drill				
20.	A105 forge purchased from Iran	28	4400		Drilling NC	2	20000	40000	Pillar drill				
21.	A105 forge purchased from Abroad				Lathe with Jigs and Fixtures NC	2.5	15500	38750	Pillar drill				
22.	A105 forge purchased from Abroad		98000	0.98	Lathe without Jigs and Fixtures NC	3	15500	46500	Pillar drill				
23.	A105 forge purchased from Abroad				Drilling CNC+N C	3	20000	60000	Pillar drill				
24.	A105 forge purchased from Abroad				Drilling NC	2	20000	40000	Pillar drill				
25.	A216WCB casting purchased from Iran				Lathe with Jigs and Fixtures NC	1.25	15500	19375	Radial drill				
26.	A216WCB casting purchased from Iran	5400	97200	0.95	Lathe without Jigs and Fixtures NC	1.5	15500	23250	Radial drill				
27.	A216WCB casting purchased from Iran	18			Drilling CNC+N C	1.5	20000	30000	Radial drill	1.2	8500	10200	
28.	A216WCB casting purchased from Iran				Drilling NC	1	20000	20000	Radial drill				
29.	A216WCB casting purchased from abroad	4500	81000	0.98	Lathe with Jigs and Fixtures NC	1.25	15500	19375	Radial drill				
30.	A216WCB casting				Lathe without Jigs and Fixtures NC	1.5	15500	23250	Radial				

	purchased from abroad				Lathe without Jigs and Fixtures			0	1 drill
31.	A216WCB casting purchased from abroad				NC Drilling	1.5	20000	30000	Radia 1 drill
32.	A216WCB casting purchased from abroad				CNC+N C Drilling	1	20000	20000	Radia 1 drill
33.	A350LF2 casting purchased from Iran				NC Lathe with Jigs and Fixtures	1.75	15500	27125	Radia 1 drill
34.	A350LF2 casting purchased from Iran	5700	85500	0.9	NC Lathe without Jigs and Fixtures	2.25	15500	34875	Radia 1 drill
35.	A350LF2 casting purchased from Iran				NC Drilling	2.25	20000	45000	Radia 1 drill
36.	A350LF2 casting purchased from Iran				CNC+N C Drilling	1.5	20000	30000	Radia 1 drill
37.	A350LF2 casting purchased from Abroad	15			NC Lathe with Jigs and Fixtures	1.75	15500	27125	Radia 1 drill
38.	A350LF2 casting purchased from Abroad	4800	72000	0.98	NC Lathe without Jigs and Fixtures	2.25	15500	34875	Radia 1 drill
39.	A350LF2 casting purchased from Abroad				NC Drilling	2.25	20000	45000	Radia 1 drill
40.	A350LF2 casting purchased from Abroad				CNC+N C Drilling	1.5	20000	30000	Radia 1 drill
41.	A105 forge purchased from Iran				NC Lathe with Jigs and Fixtures	2.5	15500	38750	Radia 1 drill
42.	A105 forge purchased from Iran	4400	123200	0.93	NC Lathe without Jigs and Fixtures	3	15500	46500	Radia 1 drill
43.	A105 forge purchased from Iran				NC Drilling	3	20000	60000	Radia 1 drill
44.	A105 forge purchased from Iran				CNC+N C Drilling	2	20000	40000	Radia 1 drill
45.	A105 forge purchased from Abroad	28			NC Lathe with Jigs and Fixtures	2.5	15500	38750	Radia 1 drill
46.	A105 forge purchased from Abroad	3500	98000	0.98	NC Lathe without Jigs and Fixtures	3	15500	46500	Radia 1 drill
47.	A105 forge purchased from Abroad				NC Drilling	3	20000	60000	Radia 1 drill
48.	A105 forge purchased from Abroad				CNC+N C Drilling	2	20000	40000	Radia 1 drill

Using the collected data, we determine the numerical data of material cost indices and labor cost as input indices and the standard adaptability indices and number of output products of each method as the output indices

of DEA model. Each index is calculated as follows:

- Material cost of each method is obtained by multiplying cost of each kilogram of that material by cover weight

- Labor cost of each method is equal to the total labor cost to perform machining and drilling operations.
- Standard adaptability index of each method is equal to the rate of material adaptability used in that method.
- Number of the output product of each method in one month is specified with respect to number of labor hours in a month and duration of machining and drilling operations.

This way, to obtain number of output products of each method in a month, 192 hours of work in a month (with respect to 24 useful labor days in a month and 8 hours of work per day) was divided by the total time of machining and drilling operations. Table 4 shows numerical values of the input and output indices in each manufacturing method of body parts.

Tab. 4. Numerical Values of Input and Output Indices in Each Manufacturing Method of Cover

Indices				Indices				Indices				Indices							
Output Indices		Input Indices		Manufacturing Indices	Output Indices		Input Indices		Manufacturing Indices	Output Indices		Input Indices		Manufacturing Indices	Output Indices		Input Indices		Manufacturing Indices
No of Output Product	Compa tibility with Standards	Labor Cost	Material Cost		No of Output Product	Compa tibility with Standards	Labor Cost	Material Cost		No of Output Product	Compa tibility with Standards	Labor Cost	Material Cost		No of Output Product	Compa tibility with Standards	Labor Cost	Material Cost	
65	0.98	37 32 5	7200 0	37	78	0.95	295 75	9720 0	25	52	0.98	423 25	7200 0	13	60	0.95	345 75	9720 0	1
55	0.98	45 07 5	7200 0	38	71	0.95	334 50	9720 0	26	46	0.98	500 75	7200 0	14	56	0.95	384 50	9720 0	2
55	0.98	55 20 0	7200 0	39	71	0.95	402 00	9720 0	27	46	0.98	602 00	7200 0	15	56	0.95	452 00	9720 0	3
71	0.98	40 20 0	7200 0	40	87	0.95	302 00	9720 0	28	64	0.98	372 00	7200 0	16	66	0.95	352 00	9720 0	4
51	0.93	48 95 0	1232 00	41	78	0.98	295 75	8100 0	29	43	0.93	539 50	1232 00	17	60	0.98	345 75	8100 0	5
45	0.93	56 70 0	1232 00	42	71	0.98	334 50	8100 0	30	39	0.93	617 00	1232 00	18	56	0.98	384 50	8100 0	6
45	0.93	70 20 0	1232 00	43	71	0.98	402 00	8100 0	31	39	0.93	752 00	1232 00	19	56	0.98	452 00	8100 0	7
60	0.93	50 20 0	1232 00	44	87	0.98	302 00	8100 0	32	49	0.93	552 00	1232 00	20	66	0.98	352 00	8100 0	8
51	0.98	48 95 0	9800 0	45	65	0.9	373 25	8550 0	33	43	0.98	539 50	9800 0	21	52	0.9	423 25	8550 0	9
45	0.98	56 70 0	9800 0	46	55	0.9	450 75	8550 0	34	39	0.98	617 00	9800 0	22	46	0.9	500 75	8550 0	10
45	0.98	70 20 0	9800 0	47	55	0.9	552 00	8550 0	35	39	0.98	752 00	9800 0	23	46	0.9	602 00	8550 0	11
60	0.98	50 9800	48	71	0.9	402	8550	36	49	0.98	552	9800	24	64	0.9	372	8550	12	

20 0
0

00 0

00 0

00 0

Now, different manufacturing methods of gate valves cover are evaluated with respect to the values of input and output indices and the use of input-oriented BCC model. Table 5 shows the results of efficiency of different methods. As in an input-oriented BCC

method, efficiency condition of its manufacturing methods is to have efficiency value of 1, the research results show that only 12 out of 48 different methods to manufacture covers are effective.

Tab. 5. Efficiency Value of Different Manufacture Methods of Cover

Manufacturing Method	Efficiency		Manufacturing Method	Efficiency		Manufacturing Method	Efficiency	
	Value of Input-oriented BCC Model	Value of Input-oriented BCC Model		Value of Input-oriented BCC Model	Value of Input-oriented BCC Model			
1	0.85539		13	1.00000		25	1.00000	
2	0.81291		14	1.00000		26	0.88416	
3	0.76989		15	1.00000		27	0.80131	
4	0.84020		16	1.00000		28	1.00000	
5	0.95155		17	0.62023		29	1.00000	
6	0.91711		18	0.59129		30	0.96204	
7	0.88889		19	0.58442		31	0.91131	
8	0.94582		20	0.61537		32	1.00000	
9	0.85568		21	0.73469		33	0.89466	
10	0.84211		22	0.73469		34	0.84211	
11	0.84211		23	0.73469		35	0.84211	
12	0.898568		24	0.73469		36	0.87361	
						37		1.00000
						38		1.00000
						39		1.00000
						40		1.00000
						41		0.64046
						42		0.64964
						43		0.58442
						44		0.63528
						45		0.74406
						46		0.73469
						47		0.73469
						48		0.73708

The results indicate that score of effective units in the DEA classical models equals 1. Therefore, it is not possible to rank them. This part of the research discusses ranking of the effective manufacturing methods of gate valve cover using TOPSIS. Ranking of the 12

effective manufacturing method of cover was performed through the following steps.

Step I: Decision-making matrix is formed and Shannon's entropy weight of each index is obtained in this step. Table 6 shows the results.

Tab. 6. Decision-Making Matrix of the Effective Methods for Manufacturing gate Valve Cover

Effective Method to Manufacture Cover	Input Indices		Output Indices	
	Material Cost	Labor Cost	Standard Adaptability	No of Output Product
	(-)C1	(-)C2	(+)C3	(+)C4
13	72000	42325	0.98	52
14	72000	50075	0.98	46
15	72000	60200	0.98	46
16	72000	37200	0.98	64
25	97200	29575	0.95	78
28	97200	30200	0.95	87
29	81000	29575	0.98	78
32	81000	30200	0.98	87
37	72000	37325	0.98	65
38	72000	45075	0.98	55

39	72000	55200	0.98	55
40	72000	40200	0.98	71
Shannon's entropy weight	0.114026194	0.48871378	0.001102786	0.396157239

Step 2: Weighted non-scale decision matrix is formed in this step and ideal and anti-ideal point is specified based on it. Table 7 shows the results.

Tab. 7. Ideal and Anti-Ideal Point

Point	C1(-)	C2(-)	C3(+)	C4(+)
Ideal Point	0.032677427	0.113192336	0.0004	0.161421575
Anti-ideal Point	0.044114526	0.230403335	0.0003	0.085349338

Step 3: In this step, distance of each option to the ideal and anti-ideal options is specified, similarity index is obtained based on that, and rank of each manufacturing method is determined. Table 8 shows the results obtained from ranking effective manufacturing methods of gate valve cover.

Tab. 8. Results Obtained From Ranking Effective Manufacturing Methods of Gate Valve Cover

Rank	Similarity Index (Ce _i)	Distance to Anti-ideal Option (+Si)	Distance to Ideal Option (-Si)	Drilling	Machining	Material	Effective Methods in Manufacturing Covers
8	0.4637559	0.0702501	0.0812306	Pillar Drill	NC Lathe with Jigs and Fixtures	A350LF2 Casting Purchased from Abroad	13
10	0.2699219	0.0404039	0.1092836	Pillar Drill	NC Lathe without Jigs and Fixtures	A350LF2 Casting Purchased from Abroad	14
12	0.075657	0.0114371	0.1397333	Pillar Drill	NC Milling	A350LF2 Casting Purchased from Abroad	15
6	0.647206	0.0948425	0.051699	Pillar Drill	CNC+NC Lathe	A350LF2 Casting Purchased from Abroad	16
4	0.8665183	0.1313911	0.02024	Radial Drill	NC Lathe with Jigs and Fixtures	A216WCB Casting Purchased from Iranian Market	25
2	0.9217992	0.137733	0.0116846	Radial Drill	CNC+NC Lathe	A216WCB Casting Purchased from Iranian Market	28
3	0.8844589	0.1315967	0.0171911	Radial Drill	NC Lathe with Jigs and Fixtures	A216WCB Casting Purchased from Abroad	29
1	0.9668199	0.1379291	0.0047336	Radial Drill	CNC+NC Lathe	A216WCB Casting Purchased from Abroad	32
5	0.6532782	0.0950709	0.0504581	Radial Drill	NC Lathe with Jigs and Fixtures	A350LF2 Casting Purchased from Abroad	37
9	0.4221822	0.0613242	0.0829312	Radial Drill	NC Lathe without Jigs and Fixtures	A350LF2 Casting Purchased from Abroad	38
11	0.1954677	0.0278543	0.1146465	Radial	NC Milling	A350LF2 Casting Purchased from Abroad	39

7	0.6418525	0.0902314	0.0503483	Drill Radial Drill	CNC+NC Lathe	A350LF2 Casting Purchased from Abroad	40
---	-----------	-----------	-----------	--------------------------	-----------------	---------------------------------------	----

4. Discussion

This research evaluated different manufacturing methods of gate valve cover in Petro Tajhiz-e-Sepahan Company. It is worth mentioning that although many studies have been conducted on evaluating manufacturing methods in industrial assemblies so far, but lack of a comprehensive and complete approach is still felt (Chang and Wang, 2009). On the other hand, the literature concerning this field shows that most studies evaluated effectiveness of different manufacturing methods merely based on a single approach. Whereas, using DEA technique and VE, which is in fact a combination of qualitative, functional, and cost approaches, this research presented a model far more comprehensive than the earlier models. It should be mentioned that using this model to distinguish effective methods from ineffective ones and following the effective methods in manufacturing gate valve cover lead to creating further value for an organization. Manufacturing method No. 28 has been used in this company to manufacture covers in the company, so far. It should be mentioned that although this method is of the effective methods to manufacture covers, it is ranked second among the effective methods. Consequently, if the organization uses method No. 32 as the leading effective method, it may provide the organization with further advantages. With a view to the effective method of manufacturing covers, it can be stated that in case A350 LF2 material is purchased from Chinese market, regardless of the type of machining and drilling method, 100 percent efficiency will be achieved. Moreover, if it is possible to perform drilling using radial drills and machining using NC lathes without jigs and fixtures or NC+CNC lathes to manufacture covers, purchasing A216 WCB casting material from Iranian or Chinese markets does not make any difference at the efficiency level of 100 percent of the manufacturing methods. It should be noted that applying A105 forge in

manufacturing cover never lead to 100 percent efficiency. On the other hand, A216WCB casting is the only material that can be purchased from Iranian market and provides complete efficiency.

Conducting an overall review of the effective methods to manufacture gate valve cover reveals that material are purchased from abroad in most methods. As mentioned earlier, cost to purchase material of this part from Chinese market was calculated as 3000 Toman with respect to the exchange rate. Now, the question is considering the recent exchange rate fluctuations and increasing rate of exchange up to 4000 Toman, what impact it could have on the effectiveness of manufacturing methods. Studying different methods of manufacturing gate valve cover with respect to the 4000-Toman exchange rate shows that if exchange rate value increases, number of the effective manufacturing methods of this part will increase to 20. This is due to increasing the methods with purchasing material from Iranian market to other effective manufacturing methods. Furthermore, the input-oriented BCC model is solved two times to study the effect of any cost index of material and labor as the inputs of DEA on efficiency of different methods of manufacturing covers. The difference is that each time one of the input indices is deleted. Where further difference is observed between the obtained efficiency and the general one, the deleted index has further impact on efficiency of manufacturing methods. The results show that the impact of material cost variable is far more than the one of labor cost variable.

5. Conclusion

This research aimed at evaluating different manufacturing methods of gate valve cover in Petro Tajhiz-e-Sepahan Company. To select evaluation indices with respect to VE approach, the overall indices used in performance evaluation in industrial assemblies were collected using authentic

scientific references and they were then classified using opinions of university professors in three engineering components, i.e. function, quality and cost. Table 2 shows the results. To identify superior indices in each component, a questionnaire was prepared and distributed among office staff of Petro Tajhiz-e-Sepahan Company and its two sister companies. Referring to the results obtained from the questionnaires and based on the relations between the three value components mentioned in Relation 1, indices of material cost, labor cost were considered as inputs and standard compatibility indices and number of output product of each method were considered as DEA model output. Finally, the problem was solved by selecting an input-oriented BCC model as a suitable model.

Evaluation of 48 different manufacturing methods of parts specified that only 12 methods had 100% efficiency. Meanwhile, manufacturing method No. 32 (A216 WCB casting purchasing from Chinese market as raw material and machining by CNC+NC lathe and drilling by radial drill) was recognized as the top method.

In this research, functional, cost and quality were three approaches that were used for evaluating different methods of manufacturing gate valve covers. Simultaneous application of these three approaches leads to complete evaluation of different manufacturing methods, as the selected method provided the company with the highest function and quality and the lowers cost. Based on this, by increasing number of output products as the major functional factor, improving quality of product on one side, and reducing manufacturing cost on the other side, in addition to the increasing internal markets share may provide an opportunity for exporting products and improve company's profitability. This leads to a boom in oil and gas equipment industry and finally leads to improving productivity of sources and national capitals.

It is necessary to mention that with respect to limitation in data collection, superior indices

of each component of VE were only considered as the important indices for evaluating efficiency of different manufacturing methods. As the research is conducted within a certain period, it is not possible to use the results obtained from analyzing its findings in a definite and permanent manner. In other words, the research findings are limited to the data collection period and they are authentic as long as no fundamental change is created in decision indices. With respect to the unstable economic conditions, changing labor wage or material procurement cost may occur over time, which consequently changes the results obtaining from evaluating manufacturing methods. As the research was conducted in Petro Tajhiz-e-Sepahan Company, the results obtained from evaluating different manufacturing methods of gate valve covers are exclusively related to the population under study and it is not possible to generalize the findings on the other companies active in oil and gas field. Having no access to the data related to standard availability index on different machining and drilling methods of covers is considered as another limitation for comprehensive evaluation of different methods of manufacturing this part. This research merely evaluated different methods of manufacturing gate valve cover and did not consider other components. Finally, evaluation and ranking of different manufacturing methods were only performed using DEA and TOPSIS.

With respect to the limitations and results, it is proposed to evaluate different manufacturing methods more comprehensively in following studies by considering further indices in all three components of VE. It is also possible to use the proposed model within different periods, compare the related results with the ones of the present research, execute the proposed performance evaluation model on manufacturing gate valve cover in other companies manufacturing oil and gas valves and compare the results with the ones of the present research. In addition to consider adaptability of the material used in each

method with a standard, considering adaptability rate of different methods of machining and drilling with their related standards paves way to a realistic evaluation of different methods of manufacturing covers. It is possible to evaluate effectiveness of different methods of manufacturing other components of gate valve and achieve a more comprehensive attitude toward how to manufacture the product effectively. Finally, on the one hand, it is possible to use other performance evaluation tools such as BSC to evaluate different methods of manufacturing covers with respect to the strategic goals of the company and on the other hand, decision-making indices in this research follow a hierarchical structure. This way, each component of VE can be divided into several indices. Based on this, it is possible to use AHP and compare its results with the ones of the present research to prioritize effective methods in manufacturing covers.

References

- [1] Ansari, M., Zareh, A. "Determining Effective Factors in Selection and Technology Transfer: Iran Khodro Body Production Line". Execution Management Dissertation (No. 1). (2009), pp. 37-56 .
- [2] Haji Zeinolabedini, M. "Value Engineering in Librarianship and Information Focusing on Information Management". Journal of Librarianship and Information. Vol 9 (No.4). (Winter 2006), pp.31-44.
- [3] Dell'Isola, A, "Scientific Application of Value Engineering in Design, Structure, Utilization, and Maintenance". Tehran. Amirkabir Industrial University Publication (Tehran Polytechnic) (Fall 2009).
- [4] Seddigh, M., Rahmani, K, Sadrnia, A. "QFD Improvement using Value Engineering (from the Perspective of Managers of East Azerbaijan Province PartManufacturing Industries)" Journal of Farasouye Modiriyat (No. 9). (Summer 2009), pp. 129-152.
- [5] Cooper V and Seiford, L. Ton. "DEA: Models and Applications". Tehran. Amirkabir Industrial University (Tehran Polytechnic).
- [6] Al-Subaie, K. Z. "Precise way to select a desalination technology." Desalination. Vol.206 (No.1-3): (2007), pp. 29-35.
- [7] Avkiran, N. K. and Parker, B . K. "Pushing the DEA research envelope." Socio-Economic Planning Sciences. Vol.44(No.1): (2010), pp.1-7.
- [8] Bokhorst, J. A. C., Slomp, J., Suresh, N. C. "An integrated model for part-operation allocation and investments in CNC technology." International journal of Production Economics .Vol.75 (No.3): (2002), pp. 267-285.
- [9] Chan, F. T. S., Chan, H. K., Chan, M. H., Humphreys, P. K. "An integrated fuzzy approach for the selection of manufacturing technologies." International Journal of Advanced Manufacturing Technology. Vol.27 (No.7-8): (2006), pp. 747-758.
- [10] Chan, F. T. S., Chung, S. H., Wadhwa, S. "A hybrid genetic algorithm for production and distribution." Omega. Vol.33 (No.4): (2005), pp. 345-355.
- [11] Chang, T. H. and Wang, T. C. "Measuring the success possibility of implementing advanced manufacturing technology by utilizing the consistent fuzzy preference relations." Expert Systems with Applications.Vol.36 (No.3): (2009), pp.4313-4320.
- [12] Charnes, A., Cooper, W. W., Rhodes, E. "Measuring the efficiency of decision making units." European Journal of

- Operational Research .Vol.2 (No.6): (1978), pp. 429-444.
- [13] Chen, I. J. and Small, M. H. "Implementing advanced manufacturing technology: An integrated planning model." *Omega*.Vol.22 (No.1): (1994), pp. 91-103.
- [14] Chuu, S. J. "Selecting the advanced manufacturing technology using fuzzy multiple attributes group decision making with multiple fuzzy information." *Computers & Industrial Engineering*. Vol.57 (No.3): (2009), pp. 1033–1042.
- [15] Cook, W. D. and Seiford, L. M. "Data Envelopment Analysis (DEA) – Thirty years on." *European Journal of Operation Research*. Vol.192 (No.1): (2009), pp. 1-17.
- [16] Cordero, R., Walsh, S. T., Kirchhoff, B. A. "Motivating performance in innovative manufacturing plants." *Journal of High Technology Management Research*. Vol.16 (No.1): (2005), pp. 89–99.
- [17] D'iaz, M. S., Machuca, J. A. D., Alvarez-Gil, M. J. "A view of developing patterns of investment in AMT through empirical taxonomies: new evidence." *Journal of Operations Management*. Vol.21 (No.5): (2003), pp. 577–606.
- [18] Datta, V., Sambasivarao, K. V., Kodali, R., Deshmukh, S. G. "Multi-attribute decision model using the analytic hierarchy process for the justification of manufacturing systems." *International journal of Production Economics*. Vol.28 (No.2): (1992), pp. 227–234.
- [19] Du, J., Liang, L., Chen, Y., Bi, G. "DEA-based production planning." *Omega*. Vol.38 (No.1-2): (2010), pp.105-112.
- [20] Efstathiades, A., Tassou, S., Antoniou, A. "Strategic planning, transfer and implementation of Advanced Manufacturing Technologies (AMT). Development of an integrated process plan." *Technovation* .Vol.22 (No.4): (2002), pp. 201–212.
- [21] Farooq, S. and O'Brien, C. "Risk calculations in the manufacturing technology selection process." *Journal of Manufacturing Technology Management*. Vol. 21 (No. 1): (2009), pp. 28-49.
- [22] Folgado, R., Pecas, P., Henriques, E. " Life cycle cost for technology selection: A Case study in the manufacturing of injection moulds" *International journal of Production Economics*.Vol.128 (No.1): (2010), pp.368–378.
- [23] Gattoufi, S., Oral,M., Kumar,A., Reisman,A. "Epistemology of Data Envelopment Analysis and comparison with other fields of OR/MS for relevance to applications " *Socio-Economic Planning Sciences* .Vol.38(No.2-3): (2004), pp.123-140.
- [24] Hofmanna, C. and Orr, S. "Advanced manufacturing technology adoption—the German experience." *Technovation*. Vol.25 (No.7): (2005), pp.711–724.
- [25] Jiang, Z., Zhang, H., Sutherland, J. W. "Development of multi-criteria decision making model for remanufacturing technology portfolio selection." *Journal of Cleaner Production*. Vol.19 (No.17-18): (2011), pp.1939-1945.
- [26] Karsak, E. E. and Kuzgunkaya, O. "A fuzzy multiple objective programming approach for the selection of a flexible manufacturing system." *International journal of Production Economics*. Vol.79 (No.2): (2002), pp.101-111.

- [27] Kengpol, A. and O'Brien, C. "The development of a decision support tool for the selection of advanced technology to achieve rapid product development." *International journal of Production Economics* .Vol.69 (No.2): (2001), pp.177-191.
- [28] Laihonon, H., Ja"askela"inen,A., Lo"nnqvist,A., Ruostela,J . "Measuring the productivity impacts of new ways of working." *Journal of Facilities Management*. Vol.10 (No. 2): (2012), pp. 102-113.
- [29] Mohanty, R. P. and Deshmukh, S. G. "Advanced manufacturing technology selection: A strategic model for learning and evaluation." *International journal of Production Economics*. Vol.55 (No.3): (1998), pp.295–307.
- [30] Oeltjenbruns, H., Kolarik, W. J., Schnadt–Kirschner, R. "Strategic planning in manufacturing systems — AHP application to an equipment replacement decision." *International journal of Production Economics*. Vol.38 (No.2-3): (1995), pp.189–197.
- [31] Orr, S. "A comparison of AMT strategies in the USA, South Africa and Germany." *International Journal of Manufacturing Technology and Management*. Vol.4 (No.6): (2003), pp.441-454.
- [32] Peças, P., Ribeiro,I., Folgado,R., Henriques,E. "A Life Cycle Engineering model for technology selection: a case study on plastic injection moulds for low production volumes." *Journal of Cleaner Production*. Vol.17 (No.9): (2009), pp.846–856.
- [33] Punniyamoorthy, M. and Ragavan, P. "A Strategic Decision Model for the Justification of Technology Selection." *The International Journal of Advanced Manufacturing Technology*. Vol.21 (No.1): (2003), pp.72-78.
- [34] Sarkis, J. "A methodological framework for evaluating environmentally conscious manufacturing programs." *Computers & Industrial Engineering* .Vol.36 (No.4): (1999), pp.793-810.
- [35] Schuh, G., Schubert, J., Wellensiek, M. Model for the Valuation of a Technology Established in a Manufacturing System. 45th CIRP Conference on Manufacturing Systems. Vol.3: (2012), pp.602–607.
- [36] Shehabuddeen, N., Probert, D., Phaal,R. "From theory to practice: challenges in operationalising a technology selection framework." *Technovation*. Vol.26 (No.3): (2006), pp.324–335.
- [37] Stock, G. N. and McDermott, C. M. "Organizational and strategic predictors of manufacturing technology implementation success: an exploratory study." *Technovation* .Vol.21 (No.10): (2001), pp.625–636.
- [38] Talluri, S., Whiteside, M. M., Seipel, S. J. "A nonparametric stochastic procedure for FMS evaluation." *European Journal of Operational Research* .Vol.124 (No.3): (2000), pp.529–538.
- [39] Talluri, S. and Yoon, K. P. "A cone-ratio DEA approach for AMT justification." *International journal of Production Economics*. Vol.66 (No.2): (2000), pp.119-129.
- [40] Theodorou , P. and Florou, G. "Manufacturing strategies and financial performance—The effect of advanced information technology: CAD/CAM systems." *Omega*. Vol.36(No.1): (2008), pp.107–121.
- [41] Tuzkaya, G., Gülsün, B., Kahraman, C., Özgen, D. "An integrated fuzzy multi-criteria decision making methodology

- for material handling equipment selection problem and an application." *Expert Systems with Applications* .Vol.37 (No.4): (2010). pp.2853–2863.
- [42] Verter, V. and Dasci, A. "The plant location and flexible technology acquisition problem." *European Journal of Operational Research*. Vol.136 (No.2): (2002), pp.366–382.
- [43] Vickery, S. K., Droge, C., Markland, R. E. "Dimensions of manufacturing strength in the furniture industry." *Journal of Operations Management*. Vol.15 (No.4): (1997). PP.317-330.
- [44] Yusuff, R. M., Yee, K. P., Hashmi, M. S. J. "A preliminary study on the potential use of the analytical hierarchical process (AHP) to predict advanced manufacturing technology (AMT) implementation." *Robotics and Computer-Integrated Manufacturing*. Vol.17 (No.5): (2001), pp 421–427.